

“EVR650” Series Electrical Truck Restraint Detail

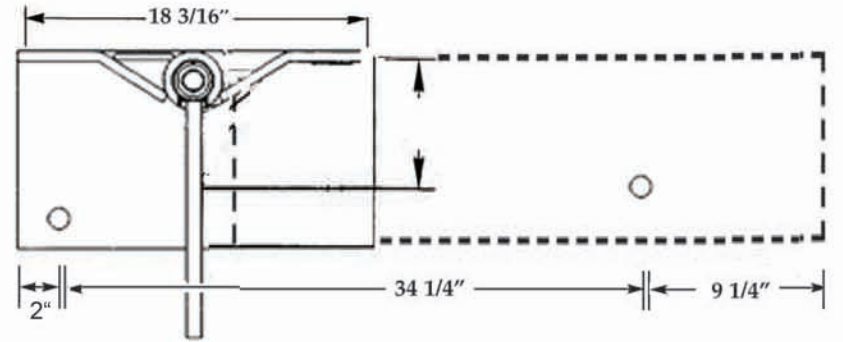

WELD HERE TO FRONT OF PIT BASE ANGLE (IF APPLICABLE)

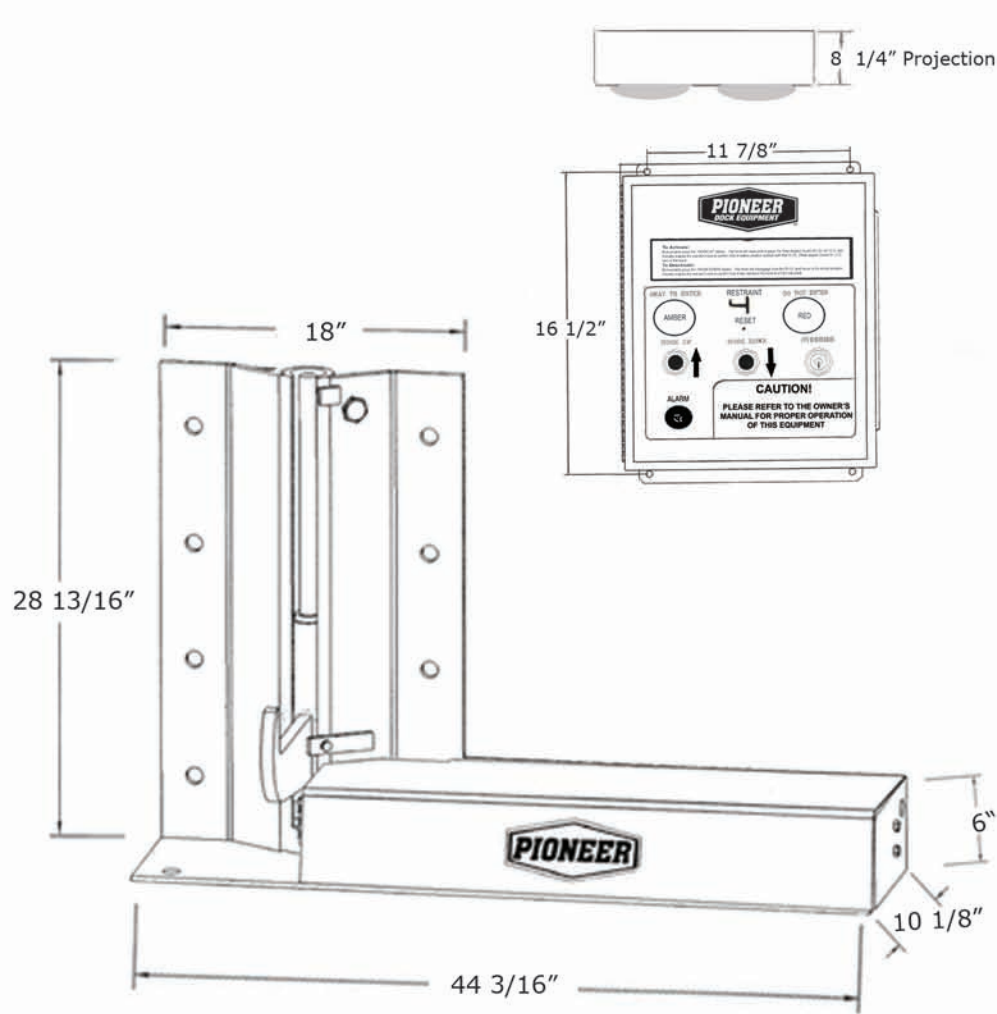

PO Box 338 • Spring Hill, Tennessee 37174
 931.486.2296 • 800.251.3382 • Fax: 931.486.0316
 www.pioneerleveler.com

JOB

“EVR650” Series Electrical Truck Restraint

08/10

STANDARD FEATURES

- ✓ Automatic unit provides in excess of 50,000 lbs. restraining force
- ✓ Wide 12” - 30” operating range
- ✓ Captures and holds all legal ICC bars
- ✓ Non-impact operation - designed to meet 1998 ICC regulations
- ✓ Positive contact hook automatically floats up or down with trailer
- ✓ Automatic inside/outside light system
- ✓ Complete inside/outside sign package included
- ✓ Bolt hole pattern designed for optional holding force
- ✓ Low maintenance
- ✓ Approximately one (1) hour installation time

(Not including electrical wiring).

OPTIONAL FEATURES

- Steel mounting plate for new construction
- Steel blockouts for bumper projections greater than 4” including edge-of-dock levelers
- Template for pre-mounting attachment bolts

INSIDE/OUTSIDE TRAFFIC DOCK LIGHT PACKAGE WARNING SIGNS

Outside Signs

CAUTION
BACK IN OR
PULL OUT
ON GREEN
LIGHT ONLY

CAUTION
PULL IN OR
TWO
ON GREEN
LIGHT ONLY

Inside Sign

CAUTION
ENTER ON
Yellow ONLY

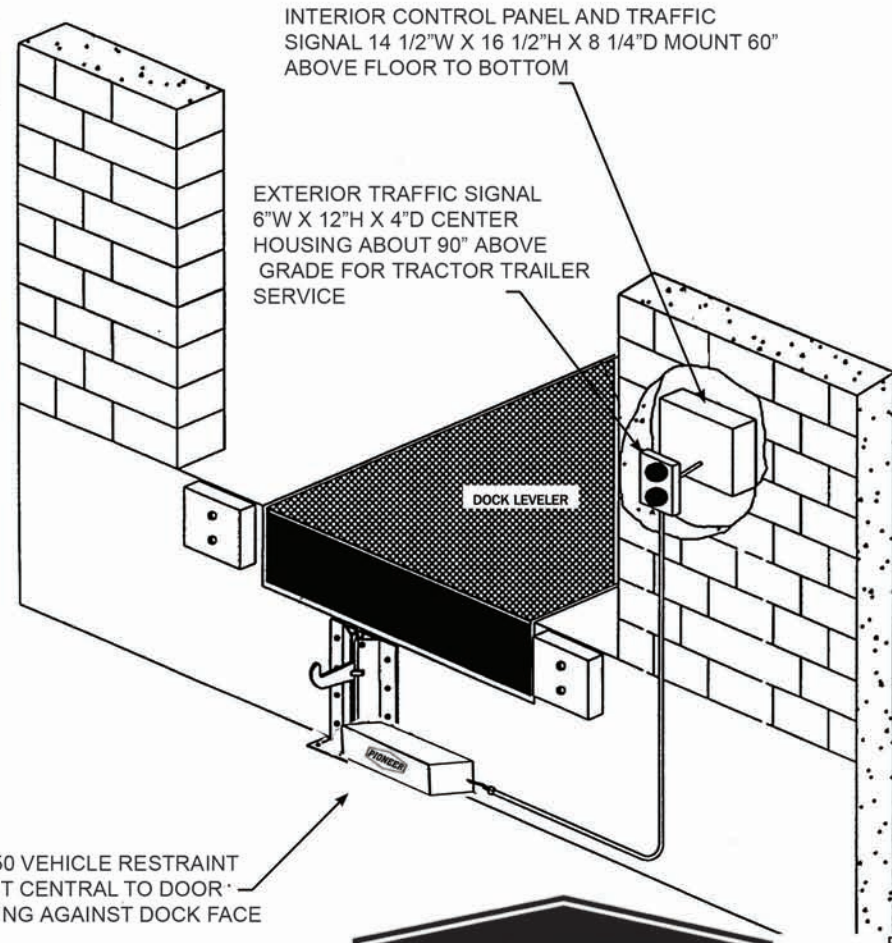
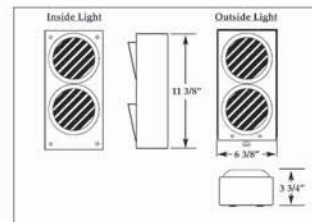

EVR650 VEHICLE RESTRAINT
MOUNT CENTRAL TO DOOR
OPENING AGAINST DOCK FACE



PO Box 338 • Spring Hill, Tennessee 37174
931.486.2296 • 800.251.3382 • Fax: 931.486.0316
www.pioneerleveler.com