



# PA1000 Airbag Dock Levelers

Owners Manual



P.O. Box 338 • Spring Hill, Tennessee 37174 • 1-800-251-3382 • fax: 931-486-0316 • [www.pioneerleveler.com](http://www.pioneerleveler.com)



# **WARNING**

**DO NOT install, operate or service product unless you have read and understand the Safety Procedures, Warnings, Installation and Operating instructions contained in this manual. Failure to do so could result in serious injury and/or death.**

## Safety Procedures



**WARNING:** Read and understand all safety practices and operating instructions Before installing, operating or servicing the dock leveler. Failure to follow the safety practices and operating instructions may result in property damage, serious bodily injury and/or death.

If you do not understand the safety procedures or the instructions, ask your supervisor to explain the safety procedures and/or teach you how to use the dock leveler.



**CAUTION:** The installer and/or operator **MUST** be very familiar with the operation, function and various parts of the PIONEER Pit Leveler **PRIOR** to installation and/or operation. If this is not the case, it is **IMPERATIVE** that the installer and/or operator read, and fully understand, the entire contents of this manual. **Be certain to read and understand all warning and caution statements contained in this manual prior to any installation, operation or servicing of this unit.**

- 1 Do not operate this equipment while under the influence of drugs or alcohol.
- 2 Do not stand in the driveway between the dock leveler and a truck backing or pulling away.
- 3 Be sure the truck wheels are chocked, or the truck is held in place by a restraining device, before attempting to load or unload the truck.
- 4 Do not use the dock leveler if it looks broken or does not seem to operate correctly. Lockout/tag out the defective equipment. Tell your supervisor immediately.
- 5 Do not operate the leveler with equipment, material or people on the platform and/or lip or in front of the leveler.
- 6 Be certain that equipment, material and/or people are not on the dock leveler before allowing a truck to pull out.
- 7 Keep clear of the dock leveler when it is moving. Never place your hands, arms, feet, or legs in the position where a moving dock leveler or a moving load could cause injury. **If in doubt, do not do it!**
- 8 If the dock leveler is not working properly, using the operation instructions in this manual, **do not use the dock leveler.** Contact your authorized PIONEER representative.
- 9 Never attempt to work under the dock leveler, for service or repair, without proper placement of maintenance strut.
- 10 Damage to the dock leveler, personal injury or death can result from abuse and/or negligent use of this equipment.
- 11 If you have any questions, or if a malfunction occurs which is not understood, ask your supervisor to contact your authorized PIONEER representative for assistance **PRIOR** to attempting any corrective measures.



**THIS IS THE SAFETY ALERT SYMBOL. IT IS USED TO ALERT YOU TO POTENTIAL PERSONAL INJURY HAZARDS. OBEY ALL SAFETY MESSAGES THAT FOLLOW THIS SYMBOL TO AVOID POSSIBLE INJURY AND/OR DEATH.**



## **WARNING**

**INDICATES A POTENTIALLY HAZARDOUS SITUATION WHICH, IF NOT AVOIDED, COULD RESULT IN SERIOUS INJURY AND/OR DEATH.**



**KEEP THIS MANUAL AND ALL SAFETY PROCEDURES IN A SECURE LOCATION WITH EASY ACCESS.**



**WARNING! READ AND UNDERSTAND THIS ENTIRE MANUAL PRIOR TO OPERATING THIS EQUIPMENT.**



**WARNING! A DOCK LEVELER CAN BE A POTENTIAL THREAT TO PERSONS AND PROPERTY, IF NOT USED PROPERLY. SAFE OPERATION IS THE RESPONSIBILITY OF THE OPERATOR.**



**WARNING! DO NOT ENTER THE AREA IN FRONT OF OR BELOW THE DOCK LEVELER. SERIOUS PERSONAL INJURY AND/OR DEATH MAY RESULT.**



**WARNING! DO NOT ATTEMPT TO INSTALL, MAKE REPAIRS OR ADJUSTMENTS. ONLY A TRAINED AND AUTHORIZED SERVICE TECHNICIAN SHOULD PERFORM REPAIRS OR ADJUSTMENTS. ONLY A QUALIFIED CONTRACTOR/SUB-CONTRACTOR SHOULD PERFORM THE INSTALLATION PROCESS. CONTACT YOUR LOCAL PIONEER DEALER FOR ASSISTANCE.**

 **WARNING**

- \*\*Before doing any electrical work, make certain the power is disconnected and the the leveler is properly tagged or locked out.**
- \*\*All electrical work must be done by a qualified technician and must meet all applicable codes.**
- \*\*If it is necessary to make troubleshooting checks inside the control panel with the power on, **USE EXTREME CAUTION.****
- \*\*Do Not place fingers or uninsulated tools inside the control box. Touching wires or other parts inside the control box could cause electrical shock, serious injury and/or death.**

## SECTION 1

## INSTALLATION INSTRUCTIONS RECEIVING AND HANDLING

RECEIVING:



Before installing the dock leveler, read and follow the safety procedures and the operating instructions. Failure to follow the safety procedures could result in serious injury and/or death.

Check for possible damage or missing parts immediately upon receipt of unit. **Note any damage or possible damage on receiving papers.**

Prepare any claims against carrier if necessary.

Notify PIONEER of any damage or missing parts.

HANDLING:

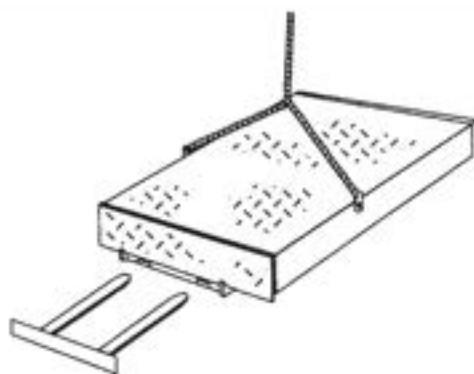

(Figure A)

Move leveler into position by using:

- chain sling inserted into side plate holes. (See Figure A) or
- fork lift, inserted in front base angle (See Figure A)
- **DO NOT FORK UNIT FROM REAR**

**NOTE:**

Control box, two bumpers, and weather seals, if applicable, are strapped under leveler. Handle with care to avoid damage to these components.

## SECTION 1

## INSTALLATION INSTRUCTIONS INSTALLATION

INSTALLATION: (Consists of 3 phases)

Pit preparation

Leveler Preparation

Leveler Installation



**Caution:** Before you start to install the leveler, use proper safety signs and barriers to separate the work area from the remainder of the dock.



Never allow anyone to stand on or near dock leveler when it is being lifted or placed into the pit. Failure to follow this warning can allow the dock leveler to fall, tip, or swing into people, resulting in serious injury and/or death.

**PIT PREPARATION AND ELECTRICAL INSTALLATION:**

**Figure B**

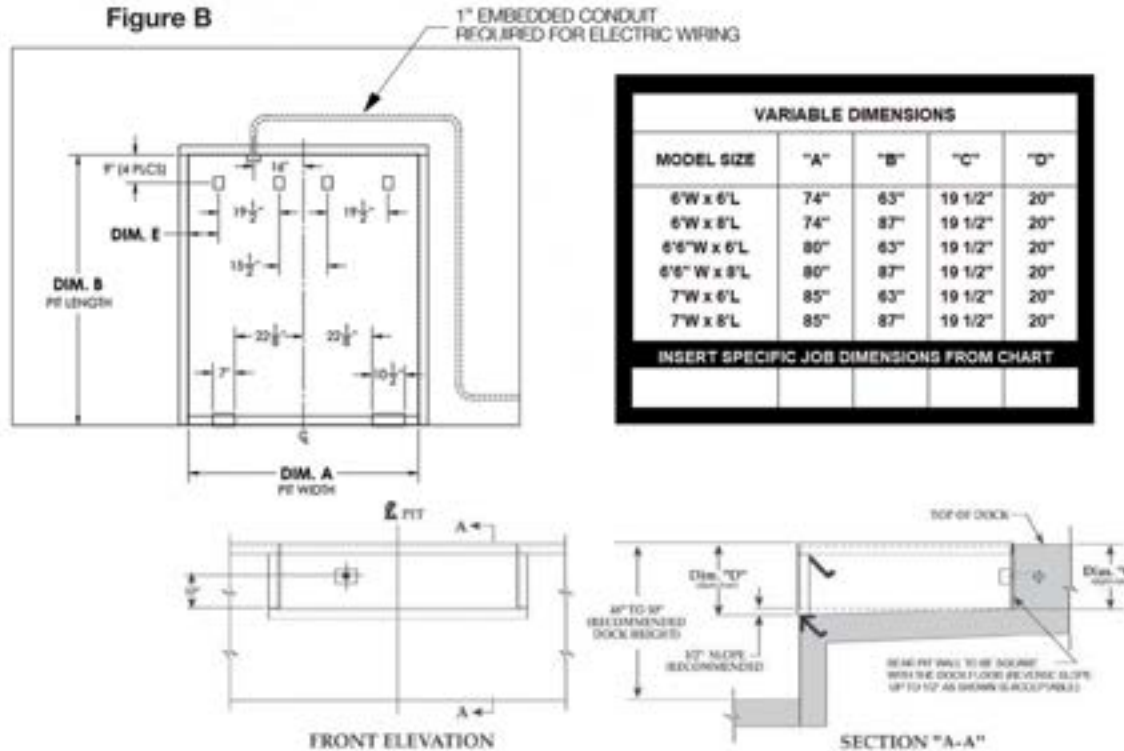

**Figure C**

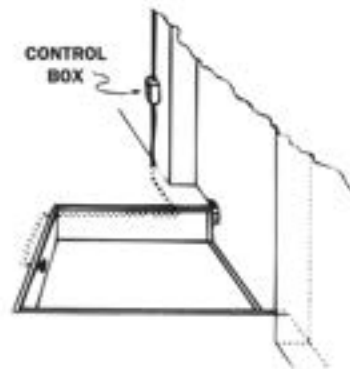

Before welding the rear frame, cover the gap between the deck section and rear frame with a piece of sheet metal to protect the air bag and weather seals (if equipped). Failure to do so may result in property damage.



Before welding in any area near the air bag, cover the bag completely with a piece of sheet metal to prevent burning holes in the bag. Failure to do so could damage or destroy bag.

1. Examine pit. Pit walls should be square and plumb. Clean all debris from pit. The floor at the rear and both sides should be level.
  2. Measure pit dimensions. (See Figure B for accurate dimensions.)  
Using a string or straight edge placed flush with the top of the pit opening, measure pit depth at locations shown in Figure B.  
[Pit depth at shim locations (minus 19") equals shims thickness.]
- NOTE:** Shims are to be placed directly under rear frame uprights and under lip keepers, See Figure B, page 3 & Figure D, page 5. Weld shims to bottom of frame prior to installing leveler in pit.
3. Install wire leads for motor per wiring diagram. (See page 17)

4. Wire must be installed through conduit. (Conduit to be supplied by customer.) Additional wire leads may be used to supply temporary power to leveler from control box. Wires for motor must be long enough to reach mid section of leveler while in front of opening. this extra may be cut back and discarded after installation.

**LEVELER PREPARATION**

 **WARNING**

Fully support the lip, while working under the leveler. The lip plate could fall causing serious injury and/or death.

 **WARNING**

Inadequate lifting equipment or practices can cause a load to fall unexpectedly. Make sure the lifting equipment is in good condition. Never allow anyone to stand on or near the dock leveler when it is lifted or placed into the pit. Stand clear of the dock leveler when it is placed into the pit. Failure to follow this warning can cause serious injury and/or death, if the dock leveler tips, swings or falls.



**CAUTION**



Route temporary power cord clear of edges and resting surfaces so that it is not damaged during lifting and placement.

1. Position leveler directly in front of pit.
2. Cut restraining band on lip.
3. Connect temporary wire leads to proper wire grouping at motor.

**NOTE:** Unit may fail to operate correctly at this point if temporary power does not supply adequate voltage. **DO NOT** make adjustments to leveler. Provide proper voltage before attempting to operate leveler. (See Electrical Page 16 & 17)



## SECTION 1

## INSTALLATION INSTRUCTIONS RECEIVING AND HANDLING

### LEVELER PREPARATION

4. Check motor operation.

Press/Twist operate button momentarily to confirm operation of motor. If motor does not operate, check connections and retry.

**NOTE:** Pan retainer bars must be removed prior to full operation of unit. (See page 8 for details)

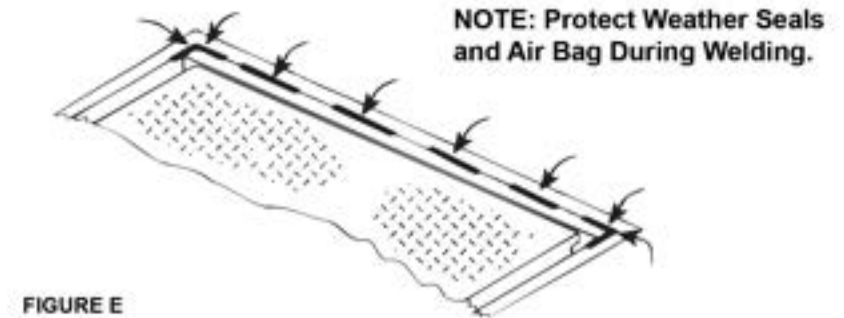
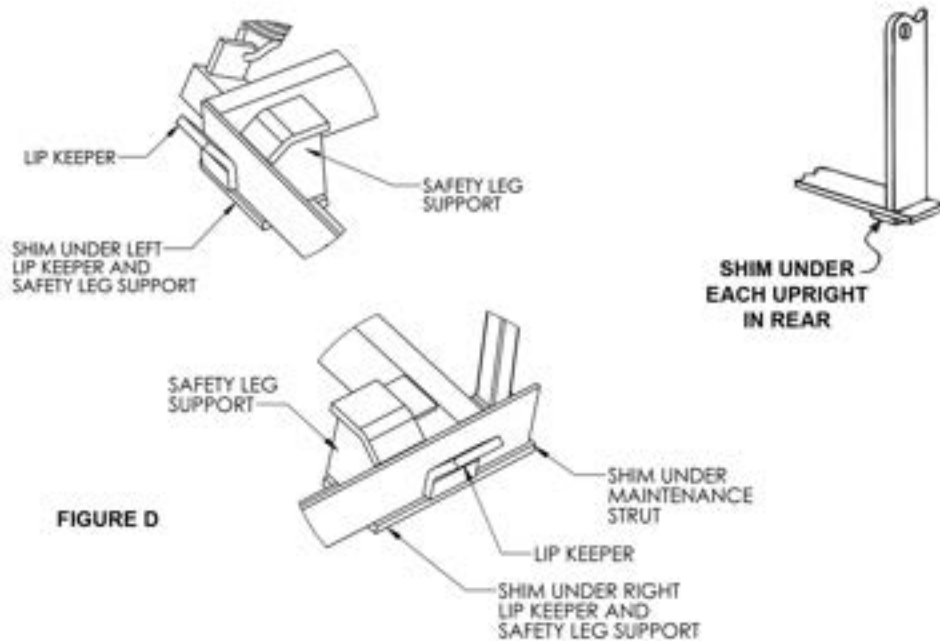

**NOTE:** Weld shims to bottom of leveler frame/base as shown prior to installing leveler in pit.

**20" Lip Keeper Installation Instructions**

Two separate lip keeper angles are provided with every unit that has a 20" lip. These angles are tack welded to the leveler base frame just behind the lip.

Break each one loose and set the leveler into the pit per the installation instructions in the owner's manual.

Prior to angle installation or shimming make sure that the unit is snug against the embedded curb angle at the back of the pit.

Place the lip keepers under the front base angle on either side of the unit with the top of the angle protruding out past the base  $\frac{1}{4}$ " in the front and on the left for the left hand keeper. This will facilitate welding. Weld right hand lip keeper on the underside of the front base angle where possible.

Fully weld the keeper angle to the base angle.

Proceed with shimming per the owner's manual.

Weld shims and lip keepers to the embedded curb angle.

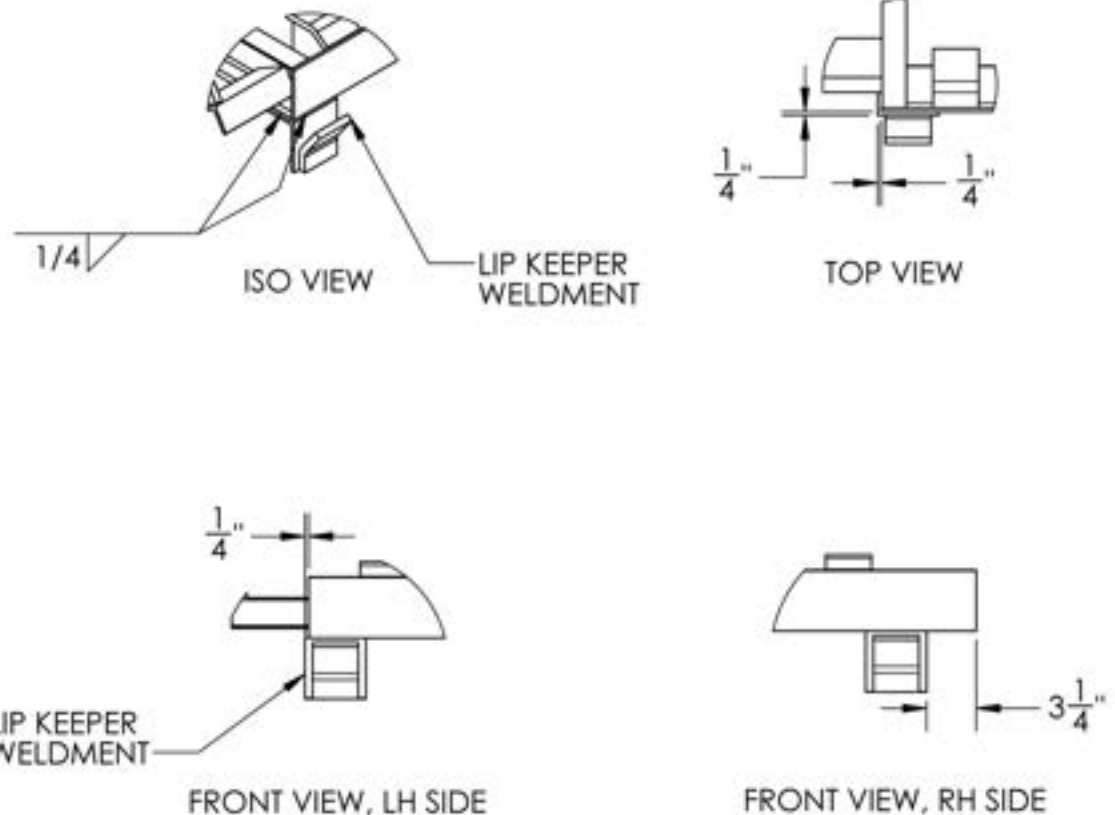

## LEVELER INSTALLATION:

 **WARNING**

DO NOT work under the dock leveler, ramp, or lip unless the maintenance strut is in place.

 **WARNING**

Keep fingers, hands, and head away from the lip when it is released. Fingers, hands, or head could be struck by or caught between the lip and other parts of the dock leveler causing serious injury and/or death.

 **WARNING**

Improper installation of this equipment or installation into aged or unsound concrete could result in serious injury and/or death.

**CAUTION**

Welding with the dock leveler's power connected can damage electrical components. If the dock leveler has previously been electrically connected, turn off power to control box and unplug all dock leveler electrical cords from receptacles in the rear pit wall before welding. Ground welder to dock leveler. Failure to do so can result in product damage.

Be certain that the rear hinge assembly is held tightly against the rear pit curb angle before welding.

**CAUTION**

If front and rear pit curb angles are not parallel DO NOT attempt to shim dock leveler supports to match pit angles. The front supports and rear frame angle must be parallel for proper operation of the dock leveler. Add or subtract shims as required.

1. Place leveler into pit opening. Position in pit about 2 feet forward of rear pit wall.

Allow one inch (1") equal clearance between leveler sides and pit walls. Rear frame angle of leveler should be tight against and flush with rear curb angle for proper welding.

2. Make permanent electrical hook up to motor.

Leveler should now be ready to operate

3. Recheck shim packs to ensure leveler is at proper height, flush with floor level, front and rear.

Shims must be placed properly under each rear frame upright and front lip keepers. (See Figure D, page 5 for close up view and Figure B, page 3 for approximate shim locations.)

Skip weld rear of leveler to curb angle (weld center first, then ends) and front shims to leveler and curb angle. (see Figure E, Page 5.) Protect rear weather seals from weld spatter if applicable.

**SECTION 1****INSTALLATION INSTRUCTIONS  
LEVELER INSTALLATION****LEVELER INSTALLATION:**

- |   |   |
|---|---|
| 4. Bring deck section of leveler to fully raised position.                          | Use temporary power, or lift slowly with fork lift under lip edge   |
| 5. Place maintenance strut securely under header plate.<br>(See figure F, page 11.) | Lift maintenance strut from its stored position under right hand side of leveler platform. Rotate it up and forward, then place it under the platform header plate as shown in Figure F, page 11. |
| 6. Weld all shims securely in place.  |   |
| 7. Connect permanent power source to control box on wall.                           |   |
| 8. Remove (Red) pan retainer bars. These are used for shipping only. (See Figure H) |   |

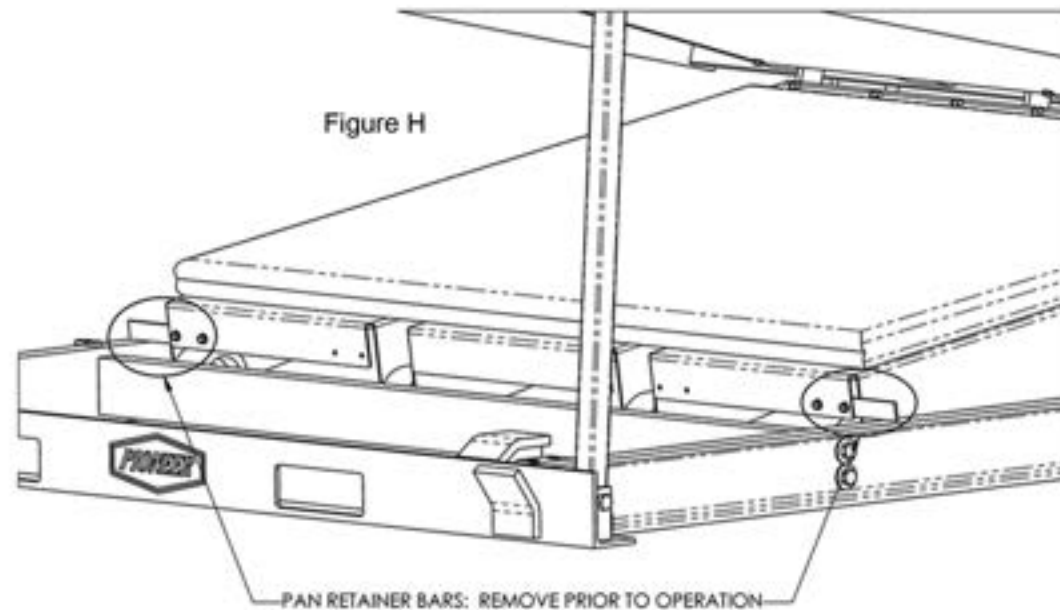

 **WARNING**

Air pressure must be maintained on the ramp to hold it in the raised position until the maintenance strut is in place. **DO NOT WORK UNDER THE DOCK LEVELER RAMP OR LIP UNLESS MAINTENANCE STRUT IS SECURED.**

 **WARNING**

Keep hands, fingers and head away from the lip when the raise button is released. The lip and dock leveler are free to move downward when air pressure is removed from the air bag.

**ABOVE DOCK USE:**

|  |   |
|--|---|
| 9. Close control box and activate leveler until lip fully extends. |   |
| 10. Store maintenance strut.                                       | Two person operation. One person holds pressure on OPERATE button while a second person stores the maintenance strut. Do not hold pressure on OPERATE button for more than 10 seconds.  |
| 11. Check that leveler raises and lip plate opens fully.           | Make sure no air leaks are present. Turn off and store in home position.  |
| 12. Install bumpers on dock face.                                  | Securely weld and bolt bumpers to dock face as close to pit opening as possible. Bumpers should be flush with dock floor or 48" off ground. Raised bumpers should be supported to floor from behind.  |
| 13. Complete weld at rear of leveler.                              | Weld shall cover approximately 50% of the length of the rear angle. Ensure welds are placed directly behind frame uprights: (4 each on 6' wide models, 6 each on 7' wide models) and at ends of angle. (See Figure E, page 5) (Protect weather seals during welding). |



**CAUTION:** Contact your PIONEER representative or the factory if a malfunction occurs which is not understood. **DO NOT** attempt to correct situation without proper information and understanding, as this may damage components and void the warranty.



 **WARNING**

ALWAYS secure the vehicle with a vehicle restraint and wheel chocks before operating the dock leveler.

- \* DO NOT operate leveler with anyone standing on or in front of leveler.
- \* DO NOT lift the leveler by hand.
- \* ALWAYS keep fingers, hands, feet, and head clear of all moving parts.

 **WARNING**

If the lip does not fall to the stored position after the truck departs, the dock leveler may require maintenance. Notify your supervisor. DO NOT use dock leveler until it has been repaired. To do so could result in serious injury and/or death.

 **WARNING**

ALWAYS be certain that the truck wheels are chocked, and that the truck is locked in place by a truck restraining device and the brakes set before loading or unloading. Visually inspect vehicle restraint to make sure it is properly engaged. Trucks pulling away unexpectedly can cause uncontrolled drop of the dock leveler, which can result in serious injury and/or death.

 **WARNING**

If the lip does not fully extend, do not lift by hand. Restore leveler to dock level and try again. If lip still does not fully extend, the dock leveler requires maintenance or adjustment. Notify your supervisor. DO NOT use the leveler until it has been repaired. To do so could result in serious injury and/or death.

 **WARNING**

Visually check that the lip is supported by the truck bed or the ramp is supported by both front lip keepers before driving or walking on the ramp.

ALWAYS return the dock leveler to its dock level (stored) position before allowing the truck to leave the dock. If the truck pulls away before the dock leveler is stored, the lip will fall to its pendant position and may not be supported by the lip keepers. In addition, failure to properly store the dock leveler may leave the leveler in a position below the level of the dock floor. These conditions may result in unexpected drop of personnel or material handling equipment and result in serious injury and/or death.

## SECTION 1

### **WARNING**

**NEVER** work under the dock leveler lip or platform without engaging the maintenance strut. If the strut cannot be engaged successfully, contact your authorized Pioneer service representative. Post safety warnings and barricade work area at the dock level and at ground level to prevent unauthorized use during maintenance/service.

#### Engaging the Maintenance Strut:

The leveler comes with a one-piece maintenance strut that must be used during inspections, maintenance, or repairs under the leveler. This stand provides support for the header plate/platform and the lip plate.

To apply the maintenance strut, a trained operator activates the leveler to raise the platform, while another lifts the strut and positions it in place beneath the header plate under the leveler platform as shown. (See Figure F).

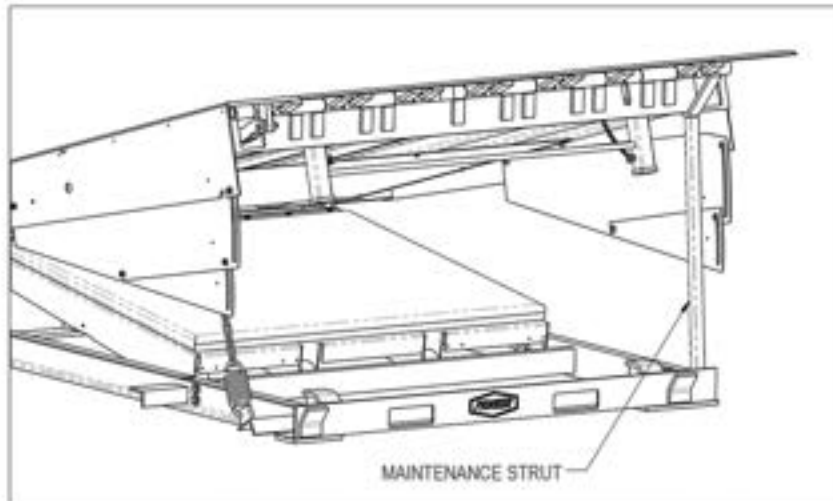

Figure F

#### Disengaging the Maintenance Strut:

After verifying that conditions are safe to disengage the maintenance strut, have a trained operator press/twist and hold the control box button. Once the platform and lip are clear of the maintenance strut, carefully lift the stand upward as far as it will move in the tube slot, then push it backward to lay it in the stored position under the leveler. (See Figure G).

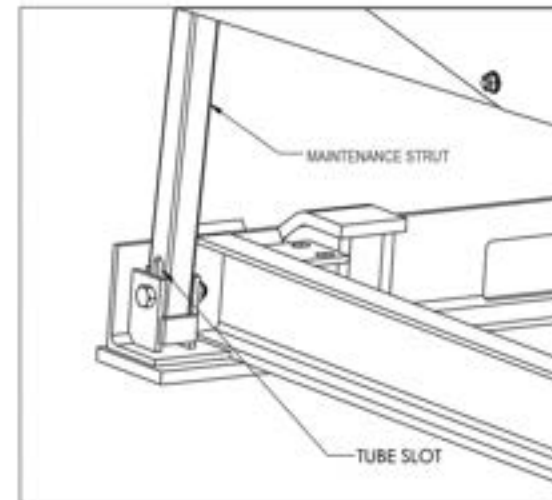

Figure G

 **WARNING**

**ALWAYS** secure the truck with a vehicle restraint or wheel chocks before operating the dock leveler. **DO NOT** operate dock leveler with anyone standing on or in front of leveler. **DO NOT** drive on dock leveler or lip until it is fully extended and supported by the truck bed. **ALWAYS** keep hands and feet clear of all moving parts. **ALWAYS** return the leveler to its safe, stored position after servicing the truck.

 **WARNING**

Before servicing the dock leveler, read and follow the Safety Practice and the operation section of this manual. Be certain, before climbing under the dock leveler, that the **MAINTENANCE STRUT** is **SECURELY IN PLACE**. (See figure F, page 11.)

**LIP EXTENDED FOR ABOVE DOCK USE**

1. Press/twist and hold the **OPERATE** button on the control box.



Push/twist the operate button to raise the leveler platform and fully extend the lip plate. When the lip plate fully extends and has locked open, release the operate button.

2. The platform will descend with lip extended until lip rests on truck bed.

 **WARNING** Do not drive on the leveler or lip until the lip is fully extended and supported by the truck bed.

3. When loading/unloading is complete, and **BEFORE** allowing the vehicle to leave, return the dock leveler to its stored position.

Push/twist the operate button and raise the leveler platform until the lip lifts and clears the truck bed and is above the lip keepers. Release the operate button and allow the platform to lower into the stored position.

 **WARNING:** Always return the dock leveler to its stored position before allowing the truck to leave the dock. If the truck leaves before the leveler is stored, the lip and platform will drop suddenly. This condition could result in an unexpected drop of equipment and personnel and could result in serious injury or death to operators and/or bystanders. 



## SECTION 2

## OPERATING INSTRUCTIONS BELOW DOCK OPERATION

### BELOW DOCK USE: (WITH LIP EXTENDED)

1. Press/twist and hold the OPERATE button on the control box.

Push/twist the operate button to raise the leveler platform and fully extend the lip plate. When the lip plate fully extends and has locked open, release the operate button.

2. As the platform descends, pull **and hold** the safety leg release ring located in the front of the deck plate (toward the lip) until the lip plate makes firm contact with the truck bed.

This will pull safety legs away from the pads they would normally contact allowing unit to go below dock.

When lip makes firm contact with the truck bed, release the front ring.

 **WARNING** Do not drive on the leveler or lip until the lip is fully extended and supported by the truck bed.

3. When loading/unloading is complete, and **BEFORE** allowing the vehicle to leave, return the dock leveler to its stored position.

Push/twist the operate button and raise the leveler platform until the lip lifts and clears the truck bed and is above the lip keepers. Release the operate button and allow the platform to lower into the stored position.



**WARNING:** Always return the dock leveler to its stored position before allowing the truck to leave the dock. If the truck leaves before the leveler is stored, the lip and platform will drop suddenly. This condition could result in an unexpected drop of equipment and personnel and could result in serious injury or death to operators and/or bystanders.



## SECTION 2

## OPERATING INSTRUCTIONS BELOW DOCK OPERATION

### BELOW DOCK USE: (LIP RETRACTED FOR END LOADS)

BELOW DOCK CONTROL OPTION IS RECOMMENDED FOR THIS OPERATION:

1. Press/twist and hold the OPERATE button on the control box.

Push/twist the operate button and raise the leveler until the platform is about half way up, being sure to release the operate button before the lip plate begins to open.

2. Pull the safety leg release ring.

As the platform descends, pull and hold the safety leg release ring located in the front of the deck plate. This will open the lip plate just enough to clear the lip keepers. Lip will be in front of keepers, and will come to rest below dock.

3. When loading/unloading is complete, return the dock leveler to its stored position.

Press/twist operate button until the lip plate is above the lip keepers. When the lip plate clears the lip keepers and fully closes, release the operate button and allow the leveler to come to rest in the stored/home position.



**CAUTION: ALWAYS SECURE LEVELER WITH LIP IN KEEPERS AND SAFETY LEGS FORWARD TO INSURE SAFE CROSS TRAFFIC USE.**



ELECTRICAL  
Motor:

1/10HP, 120V, Intermittent Duty

Control Box:

Wall mounted rotary box (115 volt/single phase only) standard. Meets N.E.M.A. 4X. Circuit protection provided by others.

| MOTOR VOLTAGE (AC) | PHASE | AMP DRAW (RUNNING) | POWER (amperage) REQUIREMENT |
|--------------------|-------|--------------------|------------------------------|
| 115                | 1     | 15.0               | 20                           |

To avoid voltage drop, Pioneer recommends #14 wire on short runs and #10 wire on long runs. See page 16.

**Consult code requirements.**



**CAUTION: A MOTOR CAN BURN OUT FOR ANY OF THE FOLLOWING REASONS:**

1. Hook up to incorrect line voltage.
2. Single phasing of polyphase motor caused by a blown fuse or loss of one leg of electrical supply.
3. Low voltage to motor due to insufficient line capacity. This is the most common with 110V, 1 ph operation.



# Choose the Right Gauge Wire

The correct wire gauge (size) for your project is based on the amperage, or power, required and the distance the wire travels. The chart below helps you determine what gauge wire you need. Remember, the smaller the number, the larger the wire. For example, a 6-gauge wire is larger than an 8-gauge wire.

| GUAGE GUIDE FOR MAXIMUM ALLOWABLE WIRE LENGTH, 2% NOMINAL VOLTAGE DROP |       |                   |            |            |            |            |            |            |            |  |
|--|-------|-------------------|------------|------------|------------|------------|------------|------------|------------|--|
|  |       | COPPER CONDUCTORS |            |            |            |            |            |            |            |  |
| AMPS   | WATTS | UP TO 50'         | UP TO 100' | UP TO 150' | UP TO 200' | UP TO 250' | UP TO 300' | UP TO 400' | UP TO 500' |  |
| 15   | 1800  | 14 Gauge          | 12 Gauge   | 10 Gauge   | 6 Gauge    | 6 Gauge    | 6 Gauge    | 4 Gauge    | 4 Gauge    |  |
| 20   | 2400  | 12 Gauge          | 10 Gauge   | 8 Gauge    | 6 Gauge    | 6 Gauge    | 4 Gauge    | 4 Gauge    | 2 Gauge    |  |
| 30   | 3000  | 10 Gauge          | 8 Gauge    | 6 Gauge    | 6 Gauge    | 4 Gauge    | 4 Gauge    | 2 Gauge    | 2 Gauge    |  |
| 40   | 4800  | 8 Gauge           | 6 Gauge    | 4 Gauge    | 4 Gauge    | 2 Gauge    | 2 Gauge    | 1 Gauge    | 1/0 Gauge  |  |
| 50   | 6000  | 6 Gauge           | 6 Gauge    | 4 Gauge    | 4 Gauge    | 2 Gauge    | 1 Gauge    | 1/0 Gauge  | 2/0 Gauge  |  |

This information is provided as a general guideline only. For safe wiring practices consult the National Electric Code, local building codes and regulations, and your local building inspector. Always remember that installation of electrical wire can be hazardous and, if done improperly, can result in personal injury or property damage.

Canadian codes differ from the above charts. Check your provincial codes before completing your project

This equipment is shipped from the factory fully tested and operative.

The majority of operating problems are caused by **IMPROPER VOLTAGE** or **UNNECESSARY ADJUSTMENT BY UNQUALIFIED PERSONNEL!**

To comply with warranty, contact your local Pioneer representative or call the factory direct if you are experiencing difficulty with the leveler during the warranty period. **DO NOT RISK VOIDING THE WARRANTY BY TAMPERING WITH THE EQUIPMENT.**

### Control Box

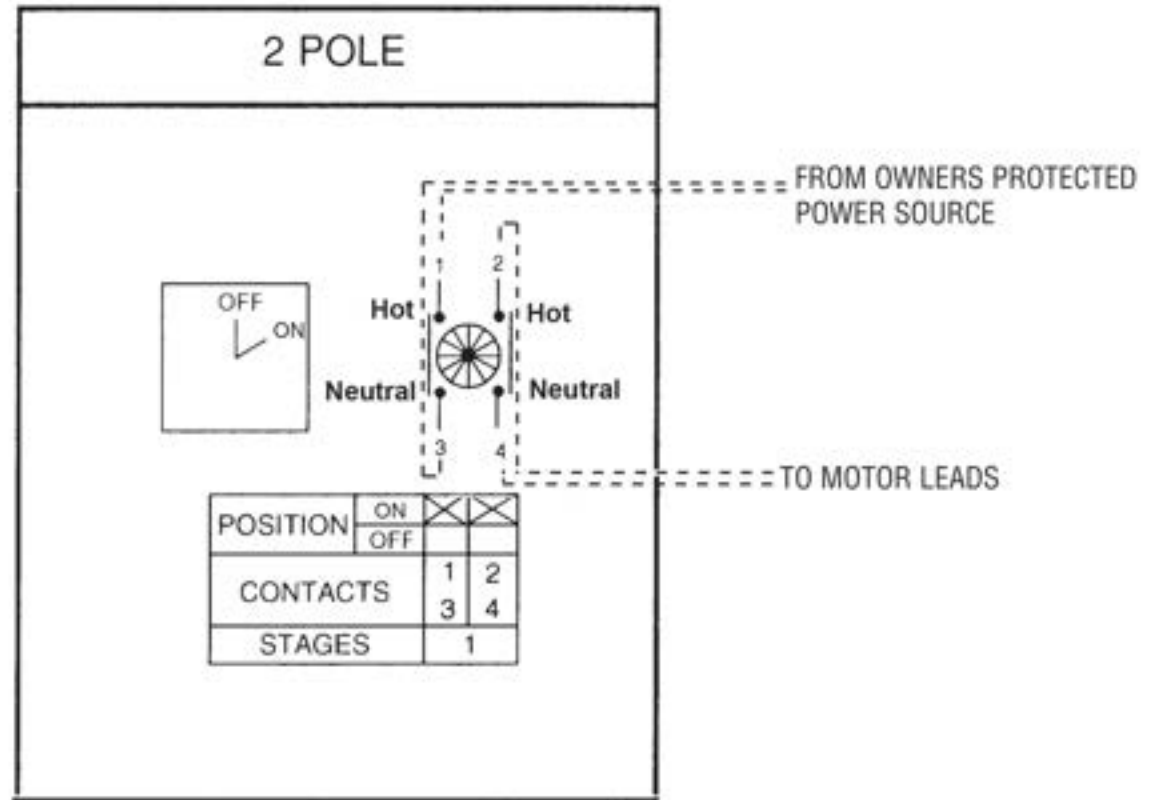

### CAUTION

Always engage maintenance strut and disconnect power before climbing under or placing hands under leveler.



**WARNING**

Read and follow the safety procedures in this manual before doing any service or repair to the dock leveler. ALWAYS SECURE LEVELER WITH MAINTENANCE STRUT BEFORE CLIMBING INTO THE DOCK LEVELER PIT OR DOING ANY MAINTENANCE OR REPAIR UNDER THE DOCK LEVELER. Failure to do so could result in serious injury and/or death.

| SYMPTOM:   | PROBABLE CAUSE:   | CORRECTION:   |
|--|---|---|
| <p>RAMP WILL NOT RAISE FROM STORED POSITION:</p> <p>Motor not running in Normal mode when Operate button is pressed.</p> | <p>1. Incorrect or disconnected electrical hook-up.</p> | <p>1. Review wiring diagram and check connections.</p>  |
|  | <p>2. Blown fuses or open circuit breaker.</p>          | <p>2. Replace bad fuses.</p> <p>Reset circuit breakers.</p> <p>Determine and correct other electrical problems.</p> |
|  | <p>3. Loss of line voltage.</p>                         | <p>3. Check lines and repair or replace if necessary.</p>   |
|  | <p>4. Burned motor.</p>                                 | <p>4. Determine cause of burn-out.</p> <p>Correct problem.</p> <p>Replace motor. (Contact factory.)</p>             |
|  |   |   |

| <b>SYMPTOM:</b>   | <b>PROBABLE CAUSE:</b>   | <b>CORRECTION:</b>   |
|---|--|--|
| <p>RAMP WILL NOT RAISE OR LIP WILL NOT EXTEND FULLY:</p> <p>Motor running or humming in normal mode</p> | <p>1. Voltage drop, probably due to insufficient line capacity, resulting in blown fuses, tripped circuit breakers or motor hum.</p> | <p>1. Test voltage with motor running. Test for amperage drain. (Low voltage/high amperage indicates inadequate feed line for distance of run.) Replace feed line with adequate wire size. (See Page 16)</p> |
|   | <p>2. Load on ramp.</p>  | <p>2. Remove the load. Ramp is not designed to lift more than its own weight.</p>  |
|   | <p>3. Motor or fan physically damaged.</p>   | <p>3. Replace.</p>   |
|   | <p>4. Air bag leaking or damaged.</p>  | <p>4. Repair or replace air bag.</p>   |
| <p>RAMP EXPERIENCES LONG DELAY BEFORE RAISING.</p>  | <p>5. Leaking or damaged air bag.</p>  | <p>5. Repair or replace air bag.</p>   |

| <b>SYMPTOM:</b>                               | <b>PROBABLE CAUSE:</b>   | <b>CORRECTION:</b>  |
|---|--|---|
| RAMP WILL NOT LOWER AFTER BEING FULLY RAISED: | 1. Physical obstruction.   | 1. Check and remove. (Always use maintenance strut for safety.)         |
| LIP CLOSES WHILE UNIT IS DESCENDING TO TRUCK: | 1. OPERATE button was released before lip was fully open and locked. | 1. Press/twist OPERATE button again until lip is fully open and locked. |
|   |  |   |



**CAUTION:**

Contact your PIONEER representative or the factory if a malfunction occurs which is not understood. **DO NOT** attempt to correct the situation without proper information and understanding as this may damage components and void the warranty.

**WARNING**

**BEFORE SERVICING THE DOCK LEVELER, READ AND FOLLOW ALL SAFETY PROCEDURES IN THIS MANUAL. FAILURE TO DO SO COULD RESULT IN SERIOUS INJURY AND/OR DEATH.**

**WARNING**

**BEFORE SERVICING THE DOCK LEVELER, ALWAYS POSITION TRAFFIC CONES OR A BARRICADE BEHIND THE DOCK LEVELER. ALSO POSITION CONES OR BARRICADES IN FRONT OF THE LEVELER TO WARN AGAINST VEHICLE TRAFFIC.**

- \* ALWAYS NOTIFY A FOREMAN OR SUPERVISOR THAT YOU ARE WORKING UNDER THE EQUIPMENT.
- \* ALWAYS MAKE SURE THAT THE MAINTENANCE STRUT IS IN POSITION BEFORE WORKING UNDER THE LEVELER.
- \* ALWAYS MAKE SURE THAT THE OVERHEAD DOOR IS SECURELY HELD IN THE RAISED POSITION.

**SERVICE AND MAINTENANCE**

Pioneer recommends periodic inspection and servicing of the PA1000 dock leveler to assure proper operation and maximum life span of the dock leveler. Units should be inspected and lubricated a minimum of every six months. (See "OPERATING INSTRUCTIONS, page 11). Contact your local Pioneer dealer to secure a complete maintenance plan.

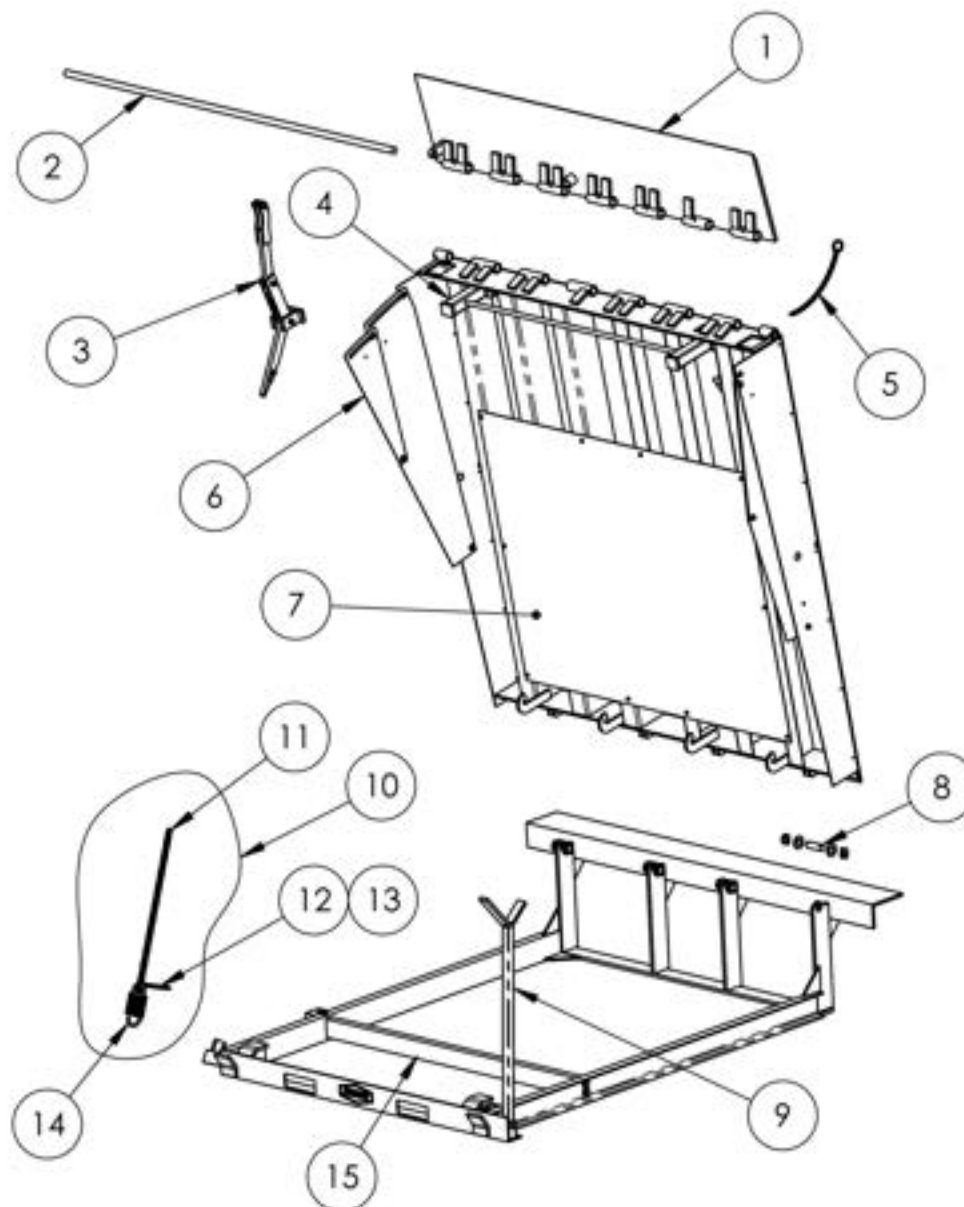
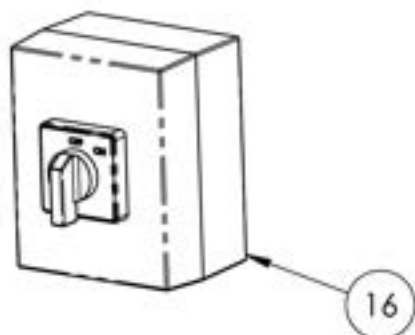

| PARTS LIST |                                   |
|------------|-----------------------------------|
| ITEM       | DESCRIPTION                       |
| 1          | LIP PLATE ASSEMBLY                |
| 2          | LIP HINGE PIN                     |
| 3          | LIP THROW OUT ASSEMBLY            |
| 4          | SAFETY LEG & MOUNTING ASSEMBLY    |
| 5          | SAFETY LEG RELEASE CHAIN ASSEMBLY |
| 6          | FULL RANGE TOE GUARDS (SET)       |
| 7          | PRESSURE PLATE, UPPER             |
| 8          | DECK REAR HINGE KIT               |
| 9          | MAINTENANCE STRUT ASSEMBLY        |
| 10         | SNUBBER CHAIN ASSEMBLY            |
| 11         | SNUBBER CHAIN                     |
| 12         | "S" HOOK                          |
| 13         | SNUBBER TENSION SPRING            |
| 14         | SNUBBER SPRING                    |
| 15         | CROSS CHANNEL ASSEMBLY            |
| 16         | CONTROL BOX                       |

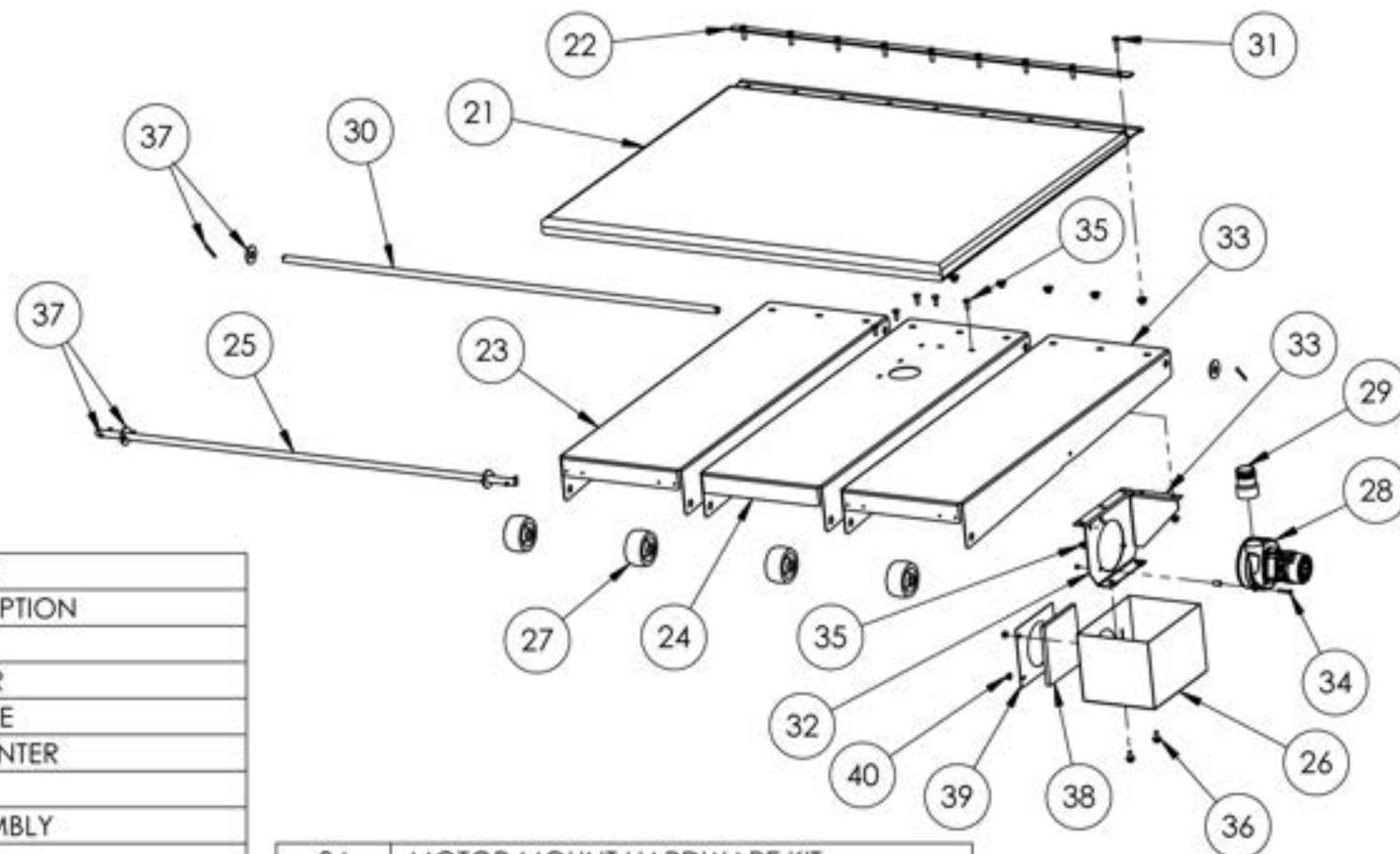

## PARTS LIST

| ITEM | DESCRIPTION               |
|------|---------------------------|
| 21   | AIRBAG                    |
| 22   | BAG RETAINER BAR          |
| 23   | SUPPORT TRAY, SIDE        |
| 24   | SUPPORT TRAY, CENTER      |
| 25   | AXLE, FRONT               |
| 26   | FAN COVER ASSEMBLY        |
| 27   | WHEEL                     |
| 28   | FAN MOTOR                 |
| 29   | ADAPTER FITTING           |
| 30   | REAR HINGE PIN            |
| 31   | BAG RETAINER HARDWARE KIT |
| 32   | MOTOR MOUNT BRACKET       |
| 33   | BRACKET SUPPORT           |

|    |                                  |
|----|----------------------------------|
| 34 | MOTOR MOUNT HARDWARE KIT         |
| 35 | BRACKET MOUNT HARDWARE KIT       |
| 36 | COVER MOUNT HARDWARE KIT         |
| 37 | AXLE RETAINER WASHER AND PIN KIT |
| 38 | REPLACEMENT FILTER ELEMENT       |
| 39 | COVER, FILTER                    |
| 40 | FILTER COVER HARDWARE KIT        |



## **Warranty Procedure**

**The information on the Warranty Claim Request Form must be provided with all warranty claims.**

When a call is received with a warranty problem a Customer Service number (CSF ####) will be issued for that problem only and cannot be used again without prior approval. This number must be on all invoices submitted for payment and on all correspondence.

Before and after pictures of all the work performed must be supplied with each claim. If you take digital pictures, e-mail them to [connerh@pioneerleveler.com](mailto:connerh@pioneerleveler.com). If you use a film camera forward the film to Pioneer Dock Equipment, PO Box 338 Spring Hill, TN 37174, Attn: Warranty Dept.

No claim will be considered for processing without the required information.

Pioneer's warranty policy for labor (one approved) requires a formal invoice from the customer performing the warranty. Pioneer must receive labor invoice within 30 days of warranty authorization. Upon receipt of labor invoice, a check will be processed.

### **Replacement Part under Warranty**

Any replacement parts will be invoiced and a credit will be given when the damaged parts are returned to Pioneer. Pioneer will determine the only exception, if the parts are not to be returned. A copy of the credit memo will be sent to your billing address. If a check payment is required the request must be in writing. The request then has to be approved by Pioneer's accounts payable department.

Replacement parts will be sent at Pioneer's discretion either UPS ground or OTR truck. Any other request for shipments will be charged to the dealer. (i.e. UPS next day - FedEx etc.)

No credits will be issued without proper authorization. No Credit will be given on non-Pioneer parts.

A copy of the credit memo will be sent to your billing address. The credit will be given against the invoice issued for the replacement parts.

Any question regarding Warranty or Return Authorization should be directed to Customer Service at [connerh@pioneerleveler.com](mailto:connerh@pioneerleveler.com) or 1.800.337.6595



## Warranty claim request form

The Following Information Must Be Supplied To Process Any Claim

Dealer Name: \* \_\_\_\_\_

Contact Person: \* \_\_\_\_\_

Pioneer Invoice Number : \_\_\_\_\_ Date Of Purchase: \_\_\_\_\_

End User Name And address:

Name: \_\_\_\_\_

Address: \_\_\_\_\_

City: \_\_\_\_\_ State: \_\_\_\_\_ Zip: \_\_\_\_\_

Product: \_\_\_\_\_

Model Number: \* \_\_\_\_\_ Serial Number: \* \_\_\_\_\_

Customer Complaint: \* \_\_\_\_\_  
\_\_\_\_\_  
\_\_\_\_\_

Scope of Service Performed: \* \_\_\_\_\_  
\_\_\_\_\_  
\_\_\_\_\_

\_\_\_\_\_

Estimated Repair: Hours: \* \_\_\_\_\_ \$ \* \_\_\_\_\_

If multiple repairs list hours and \$ for each item.

Pioneer requires an invoice for all claims requiring a payment.

**\*Before And After Pictures Must Be Supplied With All Work Performed**

Purchase a disposable camera and send it to Pioneer along with the receipt.

**\*Required to process all warranty claims.**

## **WARRANTY**

**PIONEER Manufacturing, Inc, guarantees its "PA1000" Series dock levelers to be free from defects in materials and workmanship for a period of three (3) years on structural assembly and one (1) year (365 days) on motor/fan assembly, airbag, and miscellaneous parts from date of shipment.**

**A claim for breach of warranty will be honored if the product has been properly installed, maintained and operated within its rated capacity, and not damaged by abuse. Warranty does not cover damage by freight companies. Notify carrier within 15 days of receipt of merchandise and file a claim for hidden damage.**

**PIONEER reserves the right to either repair or replace any defective parts, and will accept full responsibility for the cost of, materials and freight for such repairs. PIONEER'S STANDARD WARRANTY PROCEDURES MUST BE FOLLOWED.**

**PIONEER MANUFACTURING, INC. SHALL NOT BE LIABLE FOR LOSS OF USE OF ANY EQUIPMENT OR INCIDENTAL DAMAGES.**

**PIONEER EXPRESSLY DISCLAIMS ANY AND ALL IMPLIED WARRANTIES.**

**All PIONEER products meet or exceed Federal Occupational Safety and Health Act Standards, Commercial Standards 202-56, and American Society of Mechanical Engineers Specifications ANSI MH14.1-84.**

**Warranty Phone: 1-866-728-6195**

Pioneer reserves the right to make product improvement at any time without prior notice.