

“PA1000” Series Airbag Leveler Submittal

“PA1000” SERIES AIRBAG DOCK LEVELER MODEL SPECIFICATIONS

MODEL	LIP*	DECK*	NOMINAL LENGTH	WIDTH	HINGE CF1045	SEAMLESS HINGE TUBE	OPERATING RANGE
PA16630/PA127630	1/2" x 16"	1/4"	6'	72"/83"	1" diameter	1 5/8" dia. O.D.	+12"-12"
PA16830/PA17830	1/2" x 16"	1/4"	8'	72"/83"	1" diameter	1 5/8" dia. O.D.	+12"-12"
PA16635,40,45/PA17635,40,45	5/8" x 16"	1/4"	6'	72"/83"	1 1/8" diameter	2" dia. O.D.	+12"-12"
PA16835,40,45/PA17835,40,45	5/8" x 16"	1/4"	8'	72"/83"	1 1/8" diameter	2" dia. O.D.	+12"-12"

INSERT SPECIFIC JOB REQUIREMENTS FROM CHART

--	--	--	--	--	--	--	--

STANDARD CAPACITY

A.N.S.I. CAPACITY

--	--

*Lip and deck, 55,000 lb. minimum yield steel;
3 year structural warranty.

STANDARD FEATURES

- (2) P4H1012 Bumpers
- Lip 16"
- Grease Fittings
- Full Range Toe Guards
- Powder Coated Yellow
- Maintenance Strut
- Lip Keepers/Night Locks
- Fully Hydraulic Actuation
- Yellow & Black Diagonal Safety Stripe on Toe Guards
- Motor--115 Volt 1ph. 60Hz

OPTIONAL FEATURES

- Laminated Bumper
 - Weather Seals
 - Foam Insulation
 - Abrasive Deck
- _____
Size



PO Box 338 • Spring Hill, Tennessee 37174
931.486.2296 • 800.251.3382 • Fax: 931.486.0316
www.pioneerleveler.com

JOB

--

Pioneer reserves the right to make product improvement at any time without prior notice.

"PA1000" Series Airbag Leveler Pit Detail

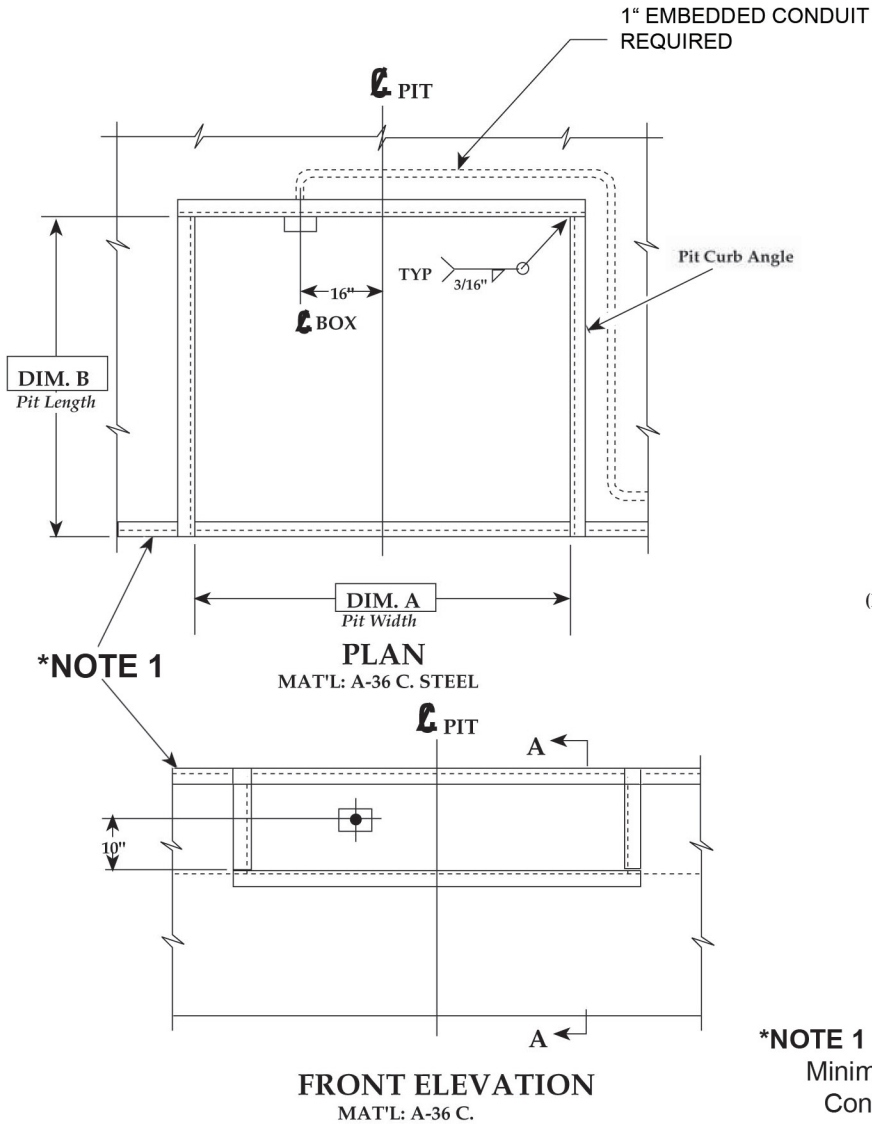

VARIABLE DIMENSIONS				
MODEL SIZE	"A"	"B"	"C"	"D"
6'W x 6'L	74"	63"	19 1/2"	20"
6'W x 8'L	74"	87"	19 1/2"	20"
7'W x 6'L	85"	63"	19 1/2"	20"
7'W x 8'L	85"	87"	19 1/2"	20"

INSERT SPECIFIC JOB DIMENSIONS FROM CHART

--	--	--	--	--

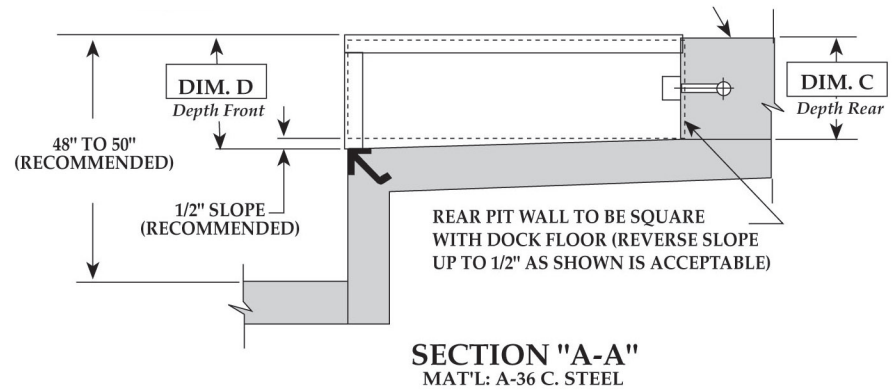

***NOTE 1 :** Angle 3"x3"x1/4"x20"
Minimum Length or Run
Continuous Pit to Pit.
(Supplied By Others)

DRAWN :	SCALE: AS NOTED	DATE: 1/30/95	DRAWING NUMBER:
---------	-----------------	---------------	-----------------

TOLERANCES		
Inch Dimension =	Decimal Dimension =	Angles = 1



PO Box 338 • Spring Hill, Tennessee 37174
931.486.2296 • 800.251.3382 • Fax: 931.486.0316
www.pioneerleveler.com

JOB

Pioneer reserves the right to make product improvement at any time without prior notice.