

SLR950 Series Automatic Truck Restraints

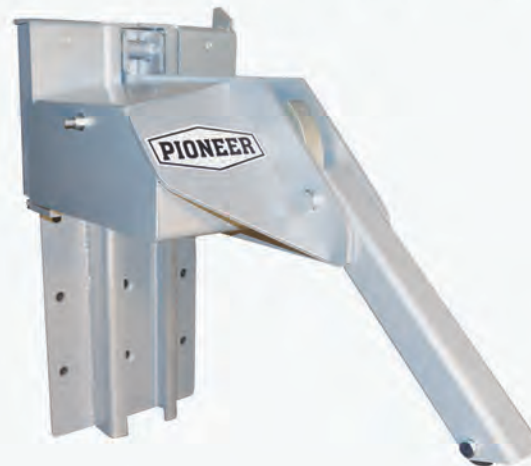

Rugged. Dependable. PIONEER.

P.O. Box 338 • Spring Hill, Tennessee 37174 • 1-800-251-3382 • fax: 931-486-0316 • www.pioneerleveler.com

The SLR950 is designed for grade mounting at dock face. Proper performance relies on adequate preparation and installation. Read the manual to fully familiarize yourself with the added value of this safety equipment. When properly installed and operated the SLR950 will provide many years of optimal service.

Be sure adequate electrical service is offered to insure proper operation of all electrical circuits.

If any information provided herein is not fully understood contact your local PIONEER representative or PIONEER direct.

This Page Intentionally Left Blank

Safety Procedures



WARNING: Read and understand all safety practices and operating instructions before installing, operating or servicing the vehicle restraint. Failure to follow the safety practices and operating instructions may result in property damage, serious bodily injury and/or death.

If you do not understand the safety procedures or the instructions, ask your supervisor to explain the safety procedures and/or teach you how to use the vehicle restraint.



CAUTION: The installer and/or operator **MUST** be very familiar with the operation, function and various parts of the PIONEER vehicle restraint **PRIOR** to installation and/or operation. If this is not the case, it is **IMPERATIVE** that the installer and/or operator read, and fully understand, the entire contents of this manual. **Be certain to read and understand all warning and caution statements contained in this manual prior to any installation, operation or servicing of this unit.**

- 1 Do not operate this equipment while under the influence of drugs or alcohol.
- 2 Do not stand in the driveway between the vehicle restraint and a truck backing or pulling away.
- 3 Be sure the truck wheels are chocked, and restrained by the SLR950, before attempting to load or unload the truck.
- 4 Do not use the vehicle restraint if it looks broken or does not seem to operate correctly. Lockout/tagout the defective equipment and tell your supervisor immediately.
- 5 Make sure the vehicle restraint is clear of all objects and debris before attempting to operate.
- 6 Be certain that equipment, material and/or people are not between the vehicle restraint and incoming/departing truck.
- 7 Keep clear of the vehicle restraint when it is moving. Never place your hands, arms, feet, or legs in the position where a moving vehicle restraint could cause injury. **If in doubt, do not do it!**
- 8 If the vehicle restraint is not working properly, as described in the operation instructions in this manual, **do not use**. Contact your authorized PIONEER representative.
- 9 Never attempt to work on the vehicle restraint, for service or repair, without proper placement of traffic barricades.
- 10 Damage to the vehicle restraint, personal injury or death can result from abuse and/or negligent use of this equipment.
- 11 If you have any questions, or if a malfunction occurs which is not understood, ask your supervisor to contact your authorized PIONEER representative for assistance **PRIOR** to attempting any corrective measures.



THIS IS THE SAFETY ALERT SYMBOL. IT IS USED TO ALERT YOU TO POTENTIAL PERSONAL INJURY HAZARDS. OBEY ALL SAFETY MESSAGES THAT FOLLOW THIS SYMBOL TO AVOID POSSIBLE INJURY AND/OR DEATH.



WARNING

INDICATES A POTENTIALLY HAZARDOUS SITUATION WHICH, IF NOT AVOIDED, COULD RESULT IN SERIOUS INJURY AND/OR DEATH.



KEEP THIS MANUAL AND ALL SAFETY PROCEDURES IN A SECURE LOCATION WITH EASY ACCESS.



WARNING! READ AND UNDERSTAND THIS ENTIRE MANUAL PRIOR TO OPERATING.



WARNING! A VEHICLE RESTRAINT CAN BE A POTENTIAL THREAT TO PERSONS AND PROPERTY, IF NOT USED PROPERLY. SAFE OPERATION IS THE RESPONSIBILITY OF THE OPERATOR.



WARNING! DO NOT ENTER THE AREA IN FRONT OF OR BELOW THE VEHICLE RESTRAINT. SERIOUS PERSONAL INJURY AND/OR DEATH MAY RESULT.



WARNING! DO NOT ATTEMPT TO INSTALL, MAKE REPAIRS OR ADJUSTMENTS. ONLY A TRAINED AND AUTHORIZED SERVICE TECHNICIAN SHOULD PERFORM REPAIRS OR ADJUSTMENTS. ONLY A QUALIFIED CONTRACTOR/SUB-CONTRACTOR SHOULD PERFORM THE INSTALLATION PROCESS. CONTACT YOUR LOCAL PIONEER DEALER FOR ASSISTANCE.

ARRANGEMENT OF THE DOCK AREA

The success and strength of any installed product relies heavily on the conditions of the material surrounding the installation site. This will include the dock face for the SLR950 Vehicle Restraint. Repair any structural defects to the dock face and/or drive prior to attempting equipment installation. If necessary, prepare alternate attachment methods to accommodate on-site conditions or contact your local representative or PIONEER to assist in preparation of accessories needed to adequately secure this product.

! WARNING

When working with electrical or electronic controls, make sure that the power source has been locked out and tagged according to OSHA regulations and approved local electrical codes.

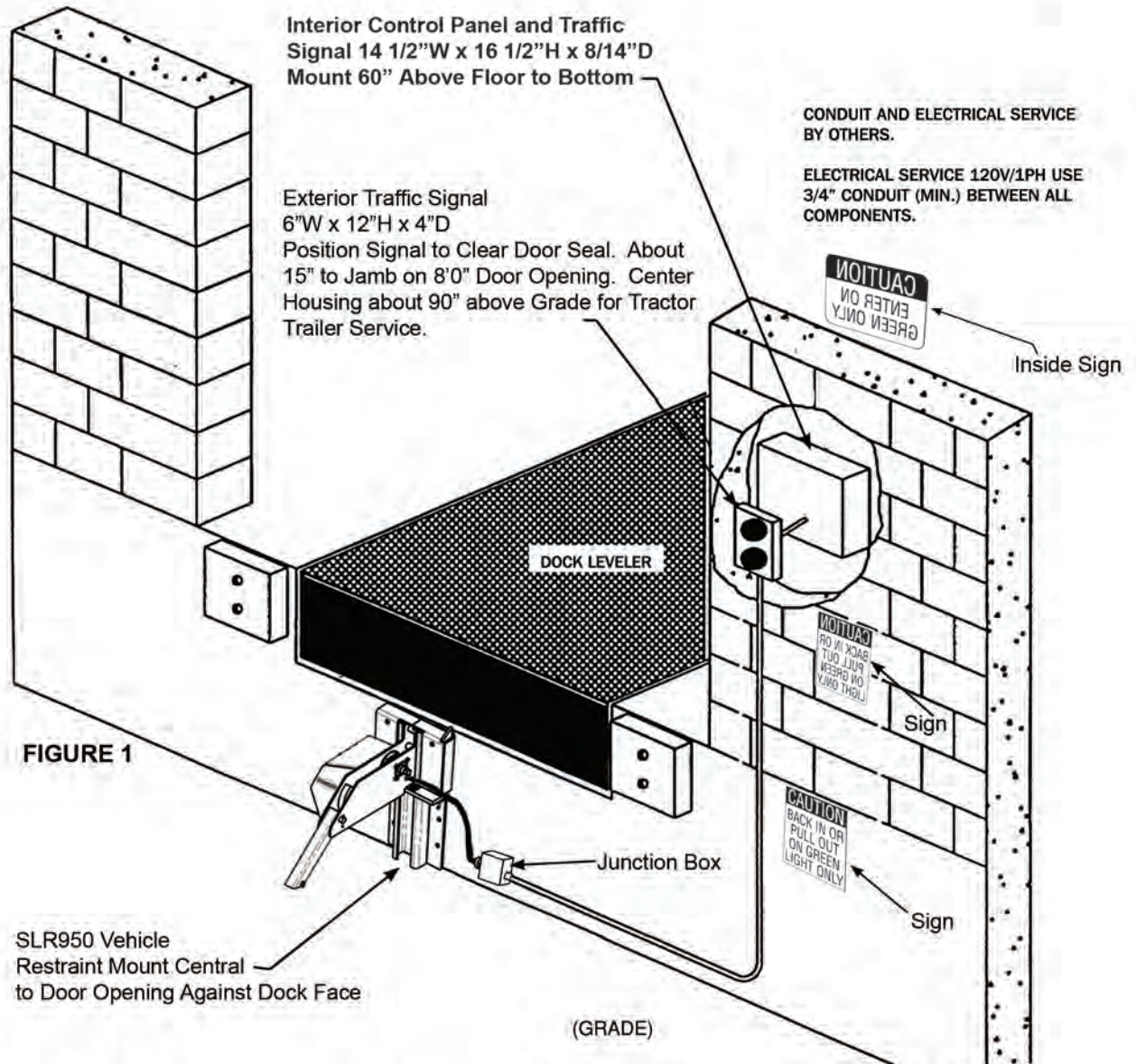

WARNING

- Before loading or unloading a trailer, while using the SLR950 truck restraint, **ALWAYS** inspect to be sure that the R.I.G. is functional so that it can be captured by the truck restraint. If a condition occurs that cannot be remedied by backing the trailer firmly against the dock bumpers, secure the trailer by other means.
- Be sure the area around the housing assembly is free of all objects, debris, or any other obstructions.
- **ALWAYS** operate the SLR950 truck restraint from the top of the dock.
- Inspect all SLR950 restraint lights daily to make certain they work properly.
- Perform maintenance on the SLR950 truck restraint in accordance with the Maintenance procedures on page 13 of this manual.
- SLR950 truck restraint should only be operated by authorized personnel who have read and understand the Owner's Manual.

WARNING

**KEEP HANDS
AWAY**



**THIS IS NOT
A STEP**



SECTION 1

INSTALLATION PROCEDURE

Read and understand all instructions prior to installation or operation of this safety equipment.

The SLR950 is shipped completely assembled and factory tested. This product displayed proper operation under factory conditions prior to shipment and is ready to install. Inspect all materials received and review arrangement layout included to preview installation setup needs.

Review the dock face area directly beneath the location where truck docking occurs. Remove or relocate any obstacles which would prevent flush and secure mounting of this product. Repair any weakness observed in the mounting area. If conditions warrant, prepare a slab for base mounting of the SLR950. Refer to page 4 for optional installation needs.

Position Restraint console and mark dock face for anchors. Unit should be positioned to sit plumb (vertical) and level (horizontal) and as firmly against dock face as possible. This unit is prepared for 5/8" x 5" wedge type anchors. (See other instructions if dock is not poured concrete construction). Fifteen (15) hole locations are provided for wall attachment and should all be prepared for anchors.

The operating range of the SLR950 offers engagement of most legally mounted R.I.G. members. The unit performance will be limited to the position and strength of the R.I.G. section which varies by manufacturer and design as well as its condition due to the extent of its maintenance, age and possible abuse. The SLR950 will accept very high stress and pulling forces, however, this too can be limited by installation technique, anchors and materials and/or the condition of the dock wall and drive area. Conditions or equipment failure due to accident or inadequate preparations and/or reasonable maintenance (see page 13, Lubrication) of the dock area and its equipment could result in further property damage or personal injury.

ARRANGEMENT OF THE DOCK AREA

NOTE: Best results for attachment of this unit will be achieved when all mounting holes are used.

OPTIONAL INSTALLATION NEEDS:

New Construction: Preplanned use of the SLR950 will afford the opportunity to use a cast in place anchor plate offered by PIONEER or prepared by others to become a fixed component of the dock face. These plates offer maximum strength and ease of installation. When embedded in a new wall or during remodeling, the SLR950 becomes a weld-on installation. Verify that the pit leveler does not extend beyond the dock face.

Leveler Overhang: Should building design offer a cantilevered dock shelf, extended bumpers or dock end mounted leveler (Edge-of-Dock product), the SLR950 Restraint console must be mounted ahead of the dock wall a distance equal to the location of the dock bumper face from the foundation wall, less 4". The console size is

designed to accommodate industry standard 4" - 6" dock bumperring. Any bumper projection more than 6" from dock face necessitates console positioning ahead of dock wall. PIONEER will prepare the SLR950 per order to satisfy your dock conditions, if known in advance. PIONEER can also prepare field adapters for these mounting needs. Discuss with your representative or local fabricator as on-site conditions require.

Cinder Block Wall: Usually a block wall offers minimal longevity to face mounted equipment. It is, therefore, necessary to take added measures to assure improved anchoring. A face plate welded to pit slab curb steel and extending to grade level with extra anchoring will be beneficial, allowing for a weld-on installation of the SLR950.

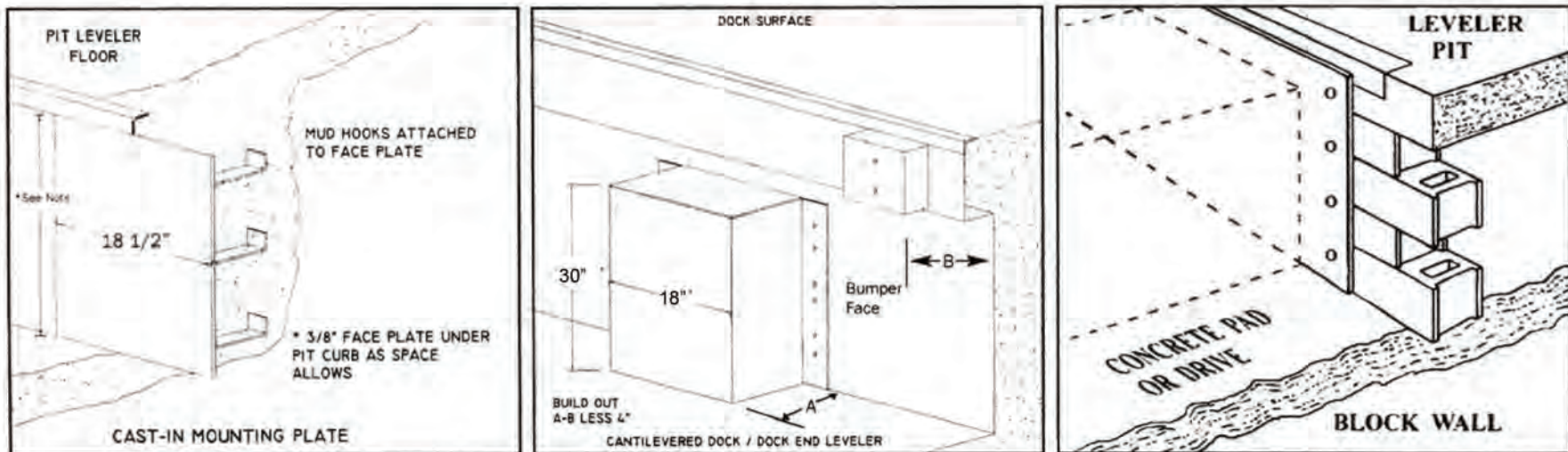



DANGER

Post safety warnings and barricade work area, at dock level and at ground level, to prevent unauthorized use of the dock position.

IMPORTANT

Whether there is a leveler or not, a 4" thick bumper is required. **DO NOT** install vehicle restraint on docks without 4" thick bumpers. For thicker bumpers consult factory.

INSTALLATION INSTRUCTIONS

An SLR950 vehicle restraint may be installed on docks with or without levelers. Consult Pioneer for proper application.

Follow the six (6) step installation procedure below:

1. Inspect the SLR950 vehicle restraint materials.
2. Install roller track plate.
3. Install SLR950 vehicle restraint into roller track plate.
4. Install electrical components.
5. Install signs.
6. Test operation.

INSPECT SLR950 MATERIALS

1. Open and inspect all materials. Immediately report any damage or material shortage. Study component assemblies and determine their proper locations.

INSTALL ROLLER TRACK PLATE

The Pioneer SLR950 vehicle restraint is shipped assembled. The track roller plate must be disassembled from the vehicle restraint to begin installation. To disassemble:

1. Remove motor cover.
2. Remove spring cover and springs. Refer to Figure 2.
3. Remove nuts from spring bar. Refer to Figure 2.
4. Roll vehicle restraint out of roller track plate. Be careful to keep rollers on the axles. Refer to Figure 2.

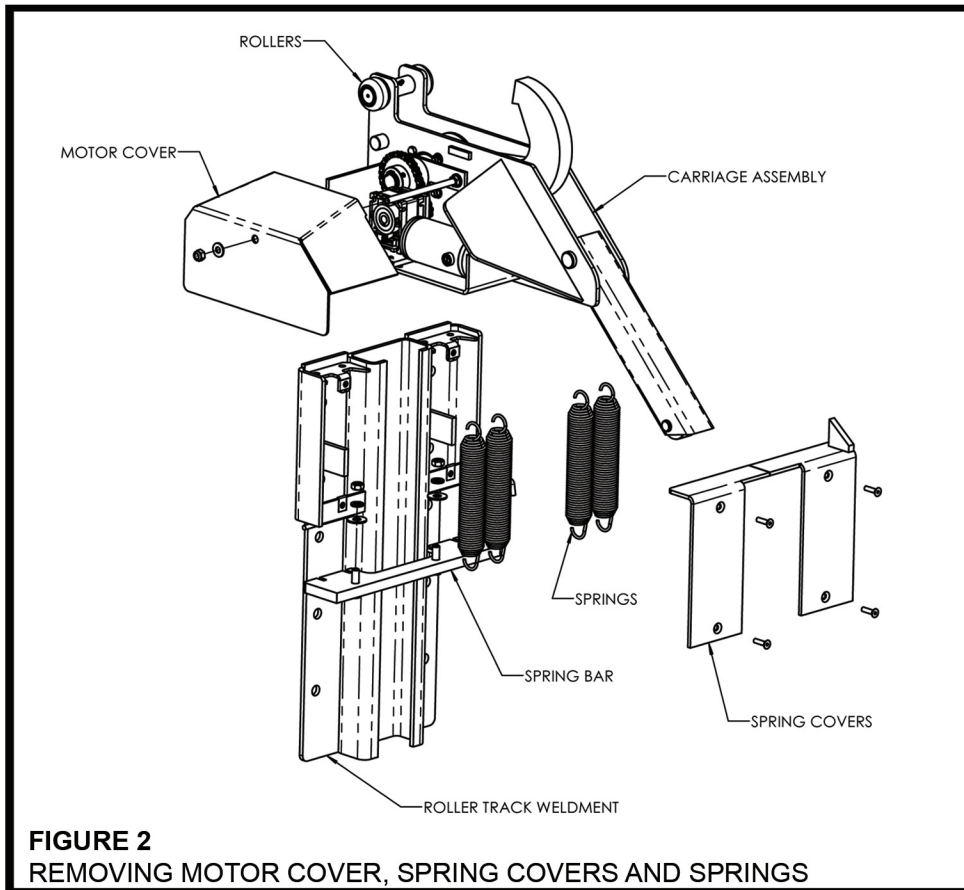

5. Install roller track plate onto dock face at specified location by welding to an embedded steel plate or by using the fifteen (15) concrete anchor holes in conjunction with welding to pit steel and a leveler frame. Refer to Figure 1 (Page 1).

For site specific installation refer to Figure 3 for further information.

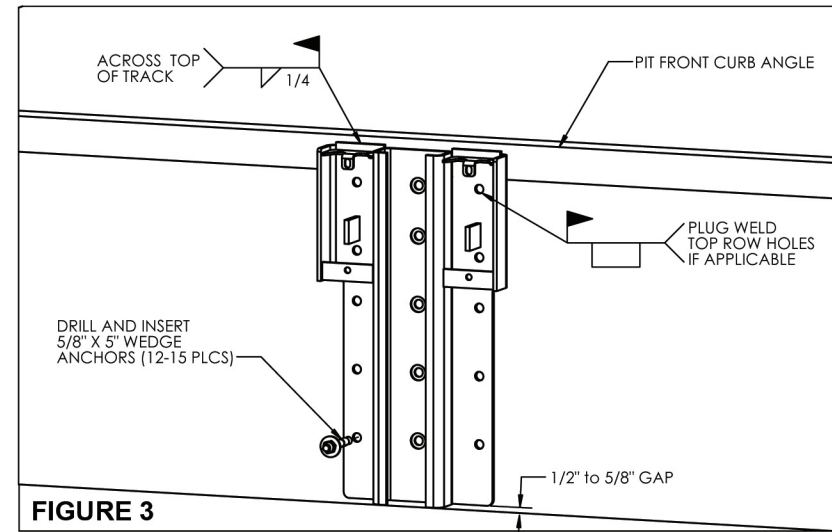

6. Re-assemble restraint assembly.

IMPORTANT

- A plumb roller track plate is required. If the dock face is not plumb/perpendicular, contact your Pioneer representative or consult factory.
- The carriage roller track cannot be bent or deformed. Straighten or replace as required.

SECTION 2

ELECTRICAL INSTALLATION INSTRUCTIONS

MOUNTING CONTROL PANEL AND OUTSIDE LIGHTS

Mount Operator Station/Control Panel in a convenient location which will provide a good view for dock attendant of loading area. We recommend left side of opening looking “out” as shown in dock arrangements diagram as this simplifies installation. Right side of doorway mounting is fine if installation conditions warrant.

Mount exterior traffic light on truck driver’s side of exterior wall (left side facing out) in area clearly visible to driver. Be certain to offer clearance for future or current installations of seal/shelter products. Light housing should be 90” above grade as noted on arrangement diagram.

Factory pre-wired junction box is inside Restraint console to harbor wire connections where control and motor leads from Operator Station will join prewired leads from console components.

Route conduit and connectors (supplied by electrical installer) to join console unit, Restraint console and exterior traffic (wire also to be supplied by installer). Make connections per diagram inside light box.

Install trucker’s instruction signs above and below traffic light where clearly visible to incoming traffic.

Supply and connect incoming electrical power to terminals within operator station.



When working with electrical or electronic controls, make sure that the power source has been locked out and tagged according to OSHA regulations and approved local electrical codes.

FIELD WIRING THE SLR950 CONTROL PANEL

The SLR950 control panel comes pre-wired, ready for field installation. All field wiring is wired directly to the terminal strip provided. Figure 4 (page 10) is an excerpt from the electrical drawings. It shows where to land the cable leads in the SLR950 control panel.

There are three items that need to be wired in the field, power, outside lights, and the motor.

Power

120VAC is wired directly to the terminal strip marked 120 VAC and NEUT. The ground lead can be wired to the GND terminal.

Outside Light

The outside light has 3 wires, one for red, one for green, and one common. Make sure that the lead for the red outside light is landed on terminal, OUT-RED. The lead for the green outside light should land on the OUT-GREEN terminal. The common wire for the outside lights should land on the - 24 VDC terminal.

Motor

A color coded motor cable is provided with each unit and is wired to the terminal strip per Figure 4. (page 10)

Contacts for Leveler Engaged Interlock Circuit (Optional)

Terminals 1 and 2 in the control panel can be used to interface with other controls. When the truck is restrained, a relay is energized, closing a set of contacts, completing the circuit between the wires connected to terminals 1 and 2. The maximum current that can be carried through this circuit is 5 amps. Land the leads for the interfacing equipment in terminals 1 and 2, it does not matter where either lead is landed.

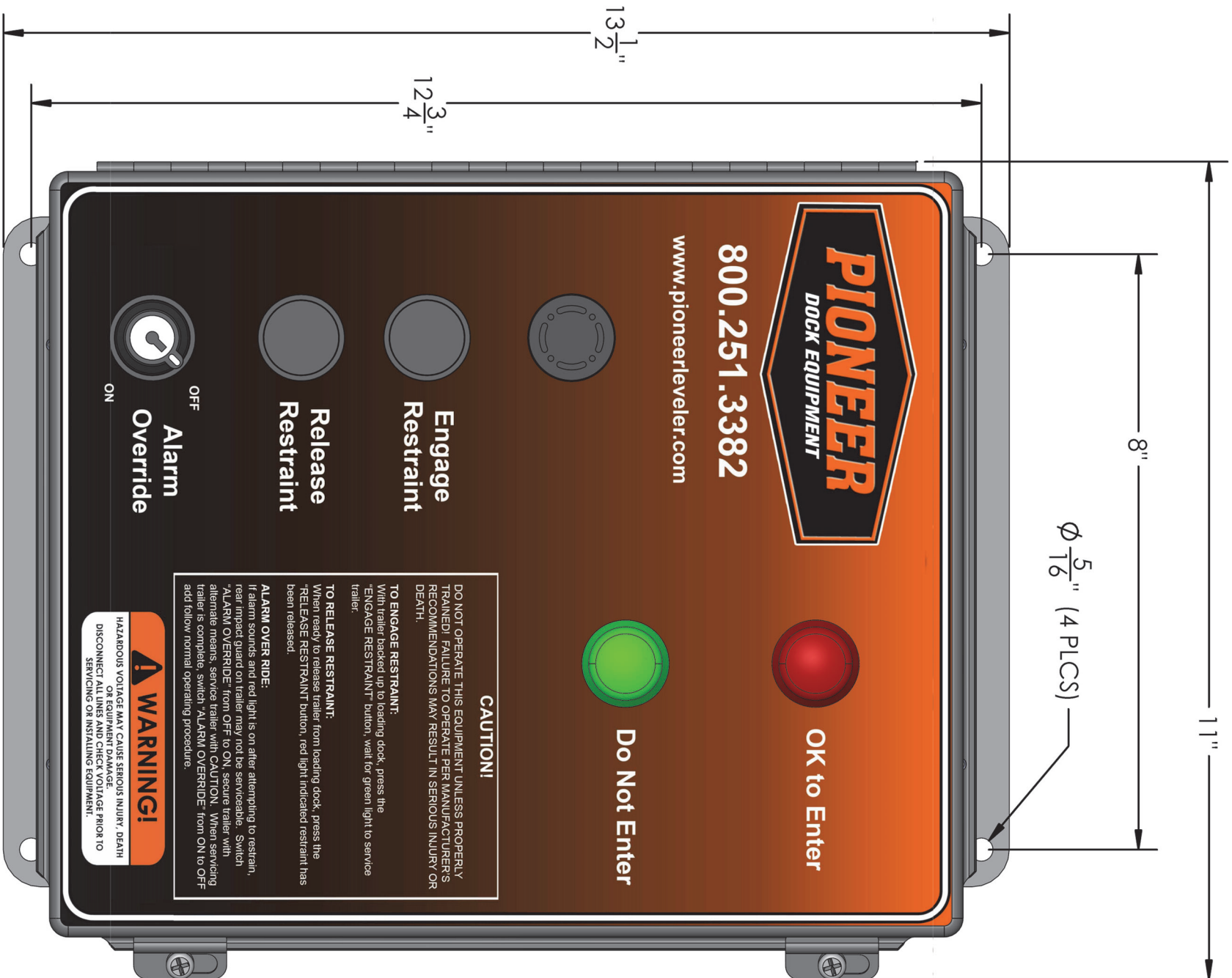

WHEN MOUNTING THE ENCLOSURE,
LEAVE THIS AREA OPEN FOR
CONDUIT OR CABLE CONNECTIONS

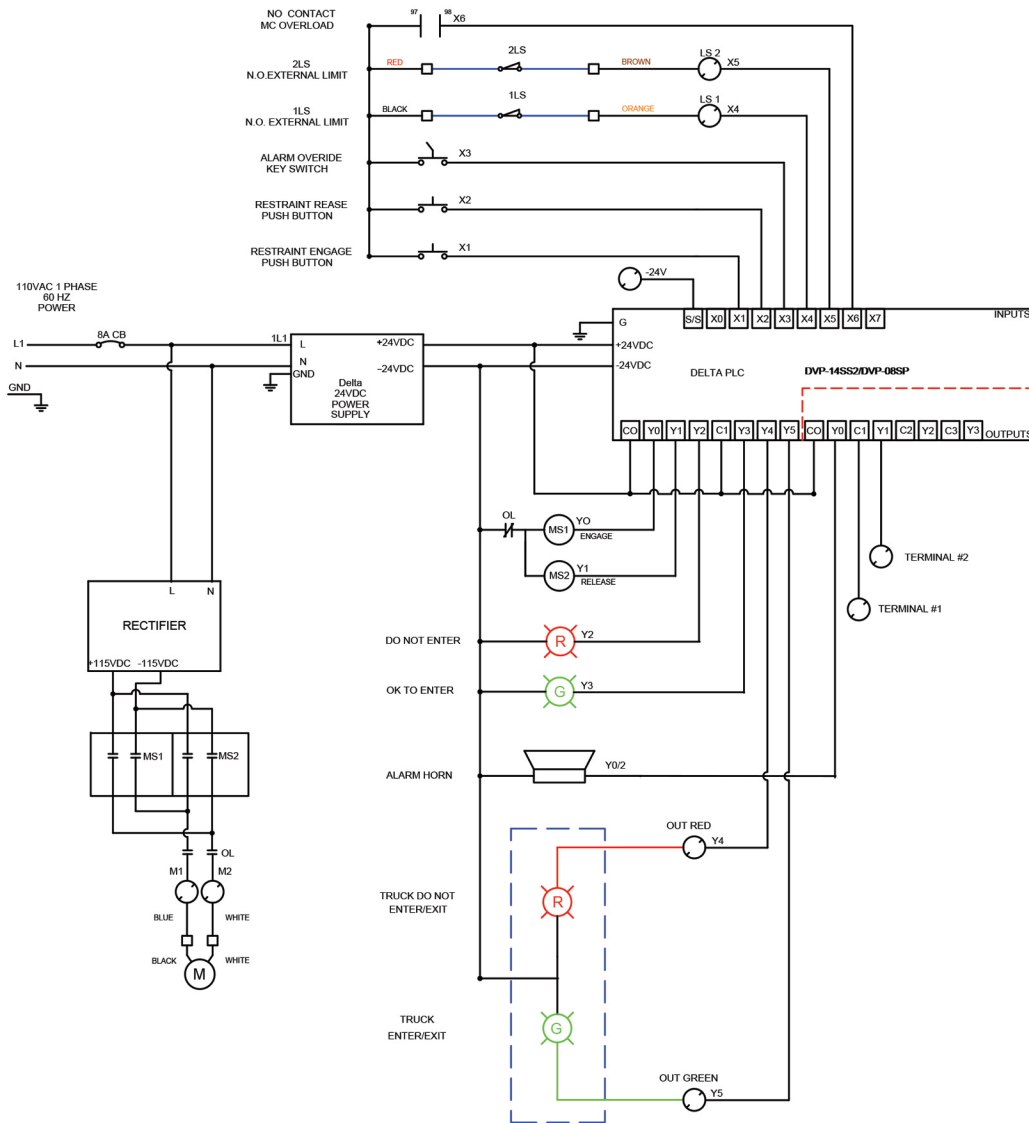

MOTOR CONNECTOR WIRING

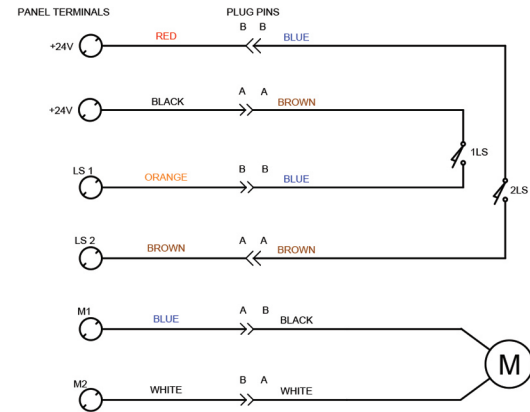

EXTERNAL LIGHT WIRING

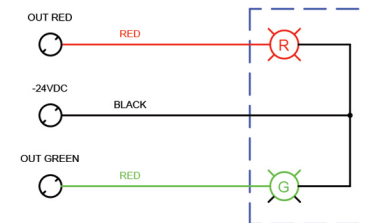

PIONEER MANUFACTURING, INC.
P.O. Box 398 SPRING HILL, TN 37174
PHONE: 600-251-3382 FAX: (631) 498-0316
DOCK EQUIPMENT

ELECTRICAL SCHEMATIC FOR 110VAC 1 PHASE SLR

PIONEER MFG.

DRAWN BY: R. Aniks	DATE: 12/6/18	DRAWING NO.: PIO-SLR-9675309
-----------------------	------------------	---------------------------------

FIGURE 4

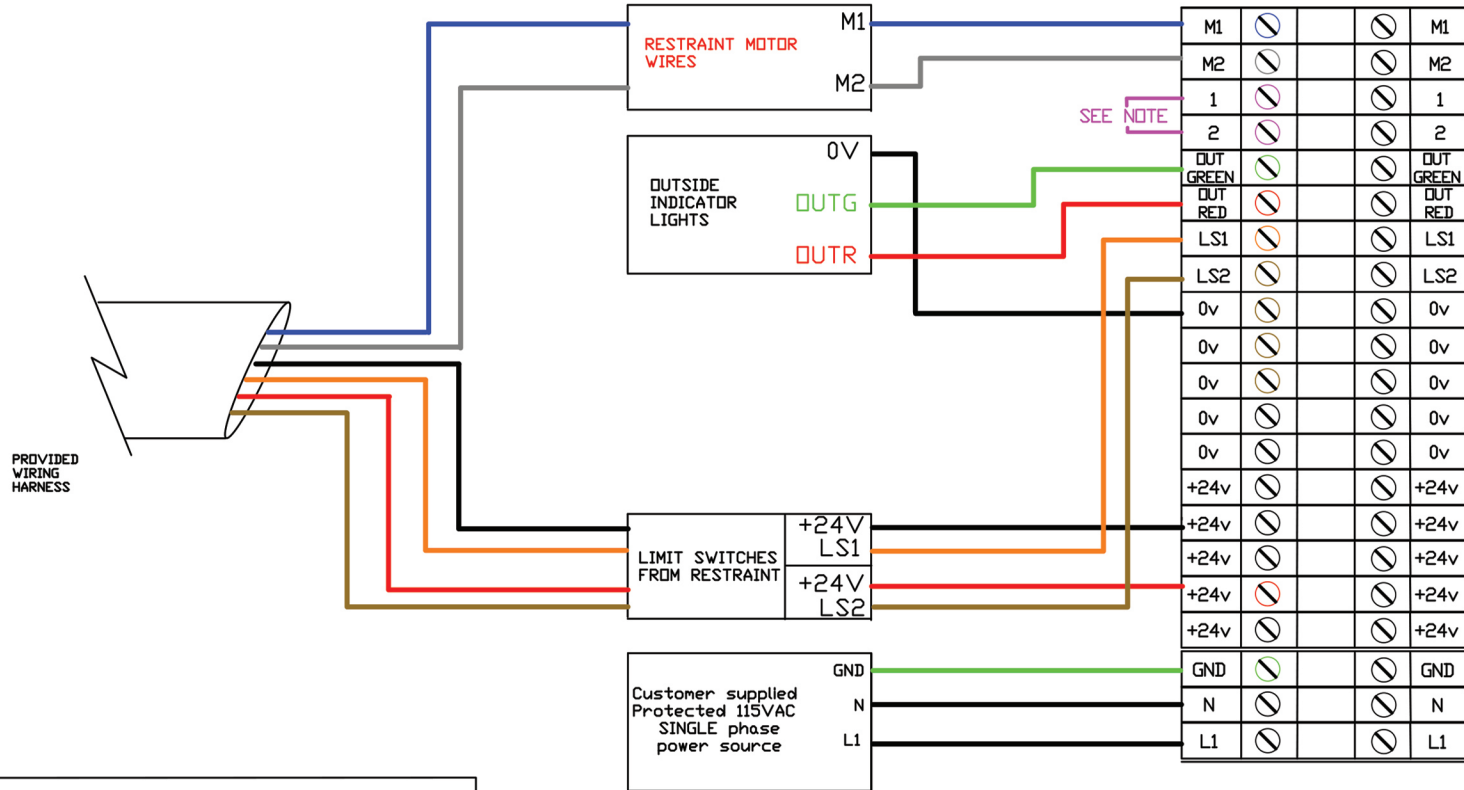

SEE NOTE

NOTE:
Terminal Blocks 1 and 2 are a NO contact that closes when the truck restraint is making positive contact with the truck's RIG bar.
For more information about this function, see Page 7 of the manual.

PIONEER MANUFACTURING, INC. P.O. Box 338 SPRING HILL, TN. 37174 PHONE:600-251-3382 FAX:(631)486-0318 LOADING DOCK EQUIPMENT	<i>Field Wiring Diagram SLR 1 phase</i>		
	PIONEER MFG.		
	DRAWN BY: R. Arks	DATE: 12/10/18	DRAWING NO.: SLR-6675309

SECTION 3

ADJUSTMENTS

Properly installed and serviced this Vehicle Restraint will greatly enhance safety during truck loading/unloading operations and should offer many years of service without a regular maintenance schedule. This product is designed for use in the outdoor environment. **Regional and seasonal climate variables offer a wide range of maintenance possibilities for equipment exposed to the elements. (See page 13, Lubrication).** The factory adjustment of this product offered proper operation prior to shipment.

Although the factory attempts to offer equipment which will display normal operation for most installations, local conditions may require attention at installation to cope with specific site needs.

Please contact the factory to review any installation or equipment issue which is not covered by this manual or which is not fully understood.

Contact your authorized PIONEER representative for required service or adjustments.

SECTION 4

OPERATION

The PIONEER Vehicle Restraint uses state-of-the-art circuitry to engage and disengage the locking hook of this unit. This system eliminates the need for regular maintenance (other than minor lubrication) although an adjustment as previously noted may be in order.

Preparing to Run

In order for the system to operate normally, the hook must be fully retracted. If the restraint hook is not fully down, turn the override key switch to override and then press and hold the hook down button until the hook travels all the way down. Once the truck restraint hook is fully retracted, turn the override key switch back to normal and the system is ready to run. In this configuration, the outside light should be flashing green, signaling the truck driver it is ok to back in. The "Do Not Enter" light will flash on the SLR950 control panel advising caution around the dock area and denying permission to enter a trailer.

Engaging or Disengaging the Truck Restraint

With the truck docked firmly **against the bumper face**, the dock attendant simply presses, the "hook up" push button momentarily, which will raise the truck restraint hook and engage the truck. Once the hook is in restraining position, the "OK to Enter" light flashes on the SLR950 control panel indicating a good loading condition. At the same time the Red outside light will begin to flash, indicating that the truck is restrained and warning the driver not to attempt a departure.

SAFETY NOTE: A brief, **visual check of the engagement** is necessary and should show the R.I.G. captured by the restraining hook of the SLR950. If the truck is noted to have a weak or missing R.I.G., the attendant should notify the dock supervisor of the problem and see that other measures are taken to secure the truck prior to loading or unloading. The SLR950 should remain engaged in order to offer a secondary safety opportunity by controlling truck traffic with its exterior traffic light.

When the "hook down" push button is momentarily pressed the restraint hook will power retract into the stored position and release the truck. NOTE: If the hook is too tight against the truck, to release, ask the truck driver to back up firmly against dock bumpers. Once the truck restraint is fully retracted, the "DO NOT ENTER" light will begin to flash on the SLR950 control panel advising caution around the dock area because the restraint is deactivated and the truck may leave at any time. The Green outside light will begin to flash, indicating that the truck is free to move.

Override Key Switch

The override key switch is used to silence alarms and manually control the motor. Turning the key to the right puts the unit in override. Turning the key to the left allows the system to operate normally.

SECTION 4

OPERATION

ALARMS

There are two (2) different fault conditions in which the alarm will be triggered. When either of these fault conditions exist, an alarm sounds and the lights on the SLR950 control panel blink in an alternating pattern. All alarms can be silenced by switching the override key to the override position. The conditions that cause alarms are given below.

1) The hook does not rotate far enough to engage the R.I.G.

If the hook comes to a stop before rotating far enough to engage the R.I.G., the alarm will sound, signaling that the hook did not engage the R.I.G. To get out of this condition, switch the override key on the control box to the on position (rotate clockwise). This turns off the alarm and allows the operator to move the hook manually by pushing the hook up or hook down buttons.

2) The hook over travels to the upper travel limit and does not engage the R.I.G.

If the hook travels to the upper stop without engaging the R.I.G., the alarm will sound, signaling that the hook did not engage the R.I.G. To get out of this condition, switch the override key on the control box to the on position (rotate clockwise). This turns off the alarm and allows the operator to move the hook manually by pushing the hook up or hook down buttons.

If either of these situations occurs and the alarm sounds, visually check the restraint hook / R.I.G. interface. If the truck is noted to have an unusually located, missing or obstructed R.I.G., turn the key to the override position and utilize other measures to secure the trailer prior to loading and unloading. If the trailer is not firmly parked against the dock bumpers, retract the hook, have trailer back up, and repeat the engagement procedure.

SECTION 5

MAJOR COMPONENTS

Restraint Carriage: A heavy steel housing, to enclose the operating components of the SLR950,

Restraint Hook: Operates to engage the R.I.G. of the trailer chassis. When engaged the Restraint hook offers resistance to truck movement. When disengaged the Restraint hook is stored within the restraint carriage to allow free passage of docking or departing vehicles.

Roller Track: Provides a guided track for vertical carriage movement. Secures carriage against dock wall.

Operating Station: A fully-gasketed steel enclosure which houses the operating push-buttons, the interior visual indicators and contains the electrical service which operates the motor and the interior/ exterior visual traffic signals.

Exterior Traffic Lights: Impact resistant enclosures for housing red and green visual traffic control indicators to display docking or no-go conditions for trucker. To open light housing, screw clamps must be loosened to service lights or wiring.

SECTION 6

SPECIFICATIONS

Electrical: 120V AC, FLA = 6.0 Amps.

Motor Unit: Right Angle DC Gear Motor

Wiring: Operator station prewired. Refer to field arrangement drawing (Page 1) for conduit and wire needs

Limit Switches: Non-Adjustable Industrial quality momentary contact type. Used to control traffic signals and logic for fault signals.

Push Buttons: Momentary contact type industrial quality switch.

Interior Lights and Exterior Lights: (Red and Green) L.E.D. 24V

SECTION 7

MAINTENANCE

Maintenance Procedure: Shut off electrical power before servicing electrical system or during lamp replacement.

Remove motor cover. Remove any debris. Inspect components for indications of potential problems (wear, damage). Make adjustments or repairs as necessary. Check chain adjustment (see figure 5 on Page 13).

Quick Check: Are all lamps on when required in cycle? Does the Restraint hook fully raise and motor stop to complete the "Lock" cycle? Does the Restraint hook fully retract and motor stop to complete "Unlock" cycle?

Visual Indicator: Proper traffic signals are critical to this safety equipment. Review functions on Page 11. Verify correct lamps on / off during lock / unlock cycles. Shut power off before lamp replacement.

Lubrication: Lubricate components regularly as shown below.

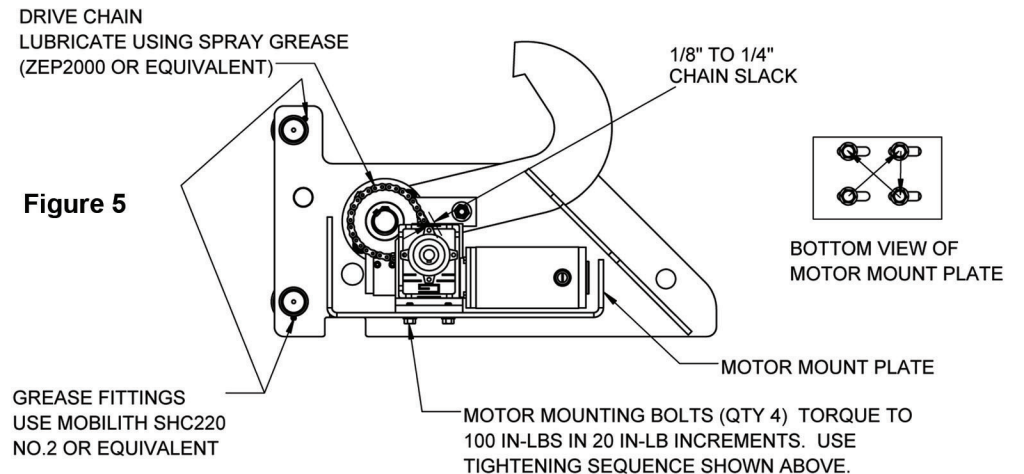

 **WARNING**

A safe work place requires all lights to be working properly. **DO NOT** use the SLR950 truck restraint if parts are broken or missing.

 **WARNING**

Post safety warnings and barricade the work area, at dock level and ground level, to prevent unauthorized use of the dock position.

 **WARNING**

When lifting unit use a proper lifting device. **DO NOT LIFT MANUALLY.** Lifting by hand may cause serious injury and/or death.

IMPORTANT

Maintenance may be required more frequently at loading docks exposed to harsh environments. Contact PIONEER if accelerated maintenance is required.

ROLLER TRACK AND SLOPE EXTENSION PARTS LIST

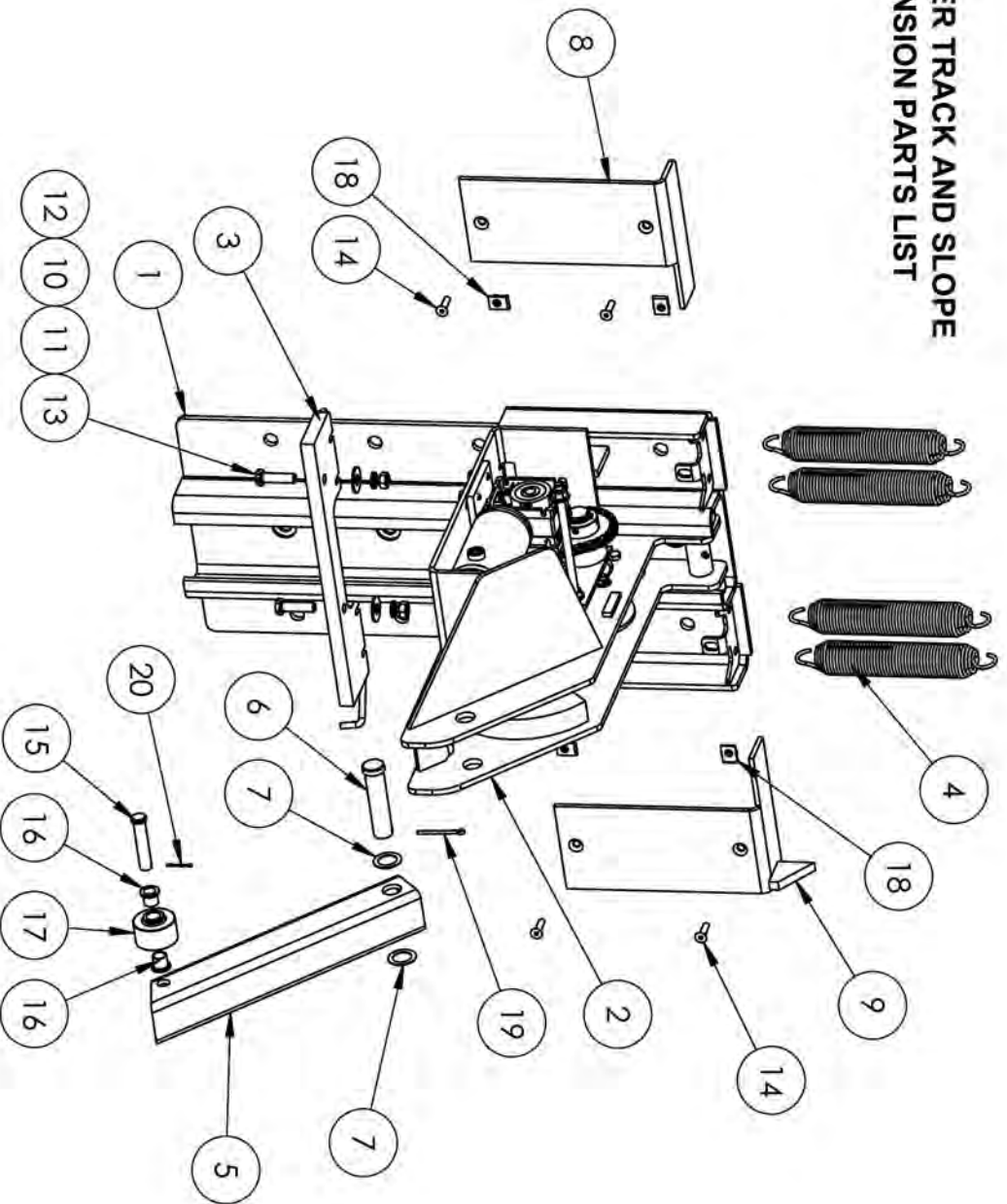

ITEM NO.	DESCRIPTION	QTY.
1	TRACK WELDMENT	1
2	CARRIAGE ASSEMBLY	1
3	SPRING MOUNT BAR WDMT	1
4	SPRING, CARRIAGE RETURN	4
5	SLOPE EXTENSION WDMT	1
6	CLEVIS PIN, 1.0 X 4.0	1
7	BUSHING, 1" ID x 1 1/2" OD x 18 GA, ZP	2
8	PLATE, SPRING COVER, LH	1
9	SPRING COVER WDMT, RH	1
10	WASHER 1/2" SPLIT LOCK	2
11	WASHER - 1/2" STD	2
12	1/2"-13 HEX NUT	2
13	SCREW, 1/2-13 X 1 3/4	2
14	SCREW, 5/16-18 X 1 1/4 FLAT HEAD	4
15	CLEVIS PIN, 5/8 X 3	1
16	BUSHING, FLANGED	2
17	WHEEL, SLOPE EXTENSION	1
18	NUT, CLIP ON, 5/16-18	4
19	COTTER KEY 3/16" X 2"	1
20	COTTER KEY 1/8" X 1"	1

**PARTS LIST
CARRIAGE ASSEMBLY**

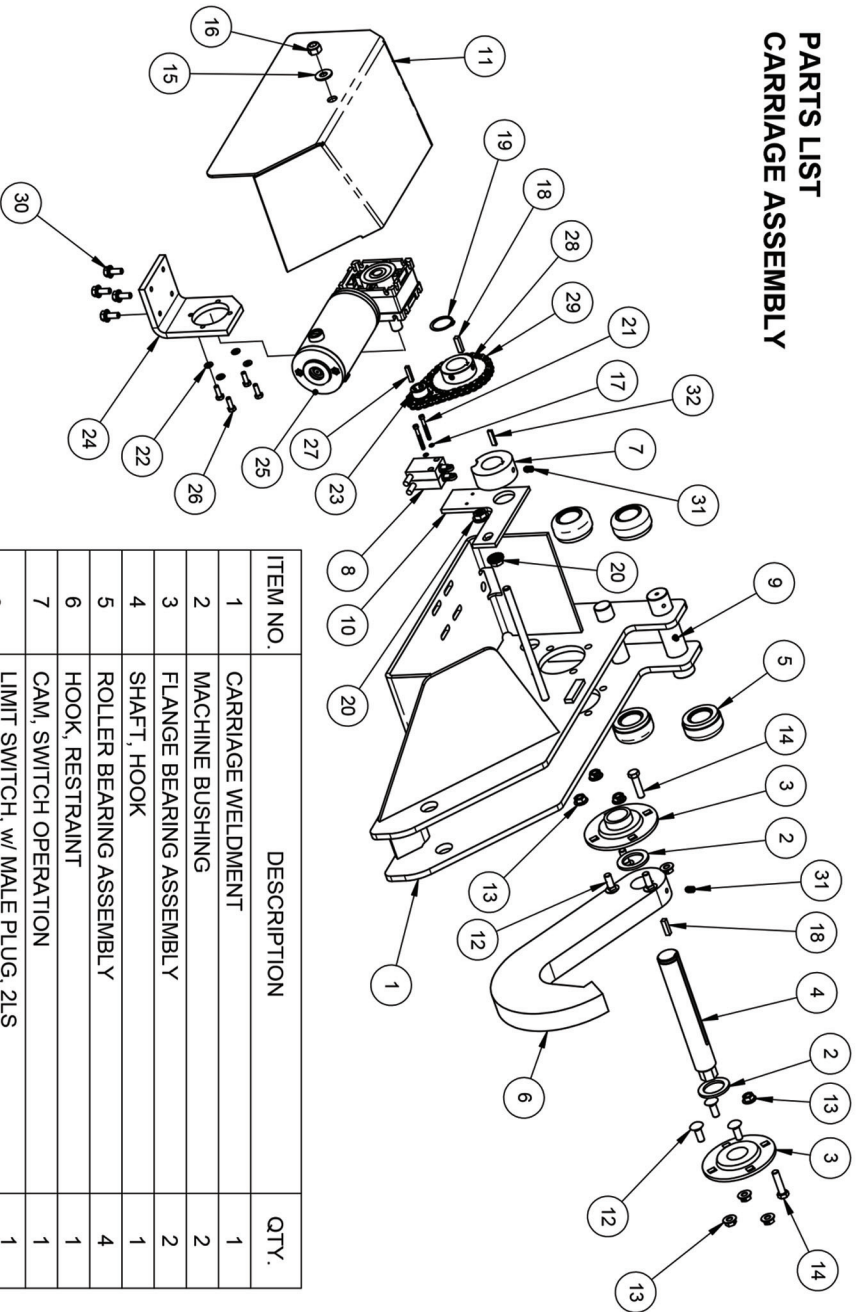

ITEM NO.	DESCRIPTION	QTY.
1	CARRIAGE WELDMENT	1
2	MACHINE BUSHING	2
3	FLANGE BEARING ASSEMBLY	2
4	SHAFT, HOOK	1
5	ROLLER BEARING ASSEMBLY	4
6	HOOK, RESTRAINT	1
7	CAM, SWITCH OPERATION	1
8	LIMIT SWITCH, w/ MALE PLUG, 2LS LIMIT SWITCH, w/ FEMALE PLUG, 1LS	1
9	GREASE FITTING	2
10	BRACKET, SWITCH MOUNT	1
11	COVER PLATE WDMT	1
12	5/16-18 X 1 CARRIAGE BOLT	6
13	LOCKNUT 3/8-16 FLANGED	8
14	3/8"-16 X 1" HEX HEAD CAP SCREW	2
15	WASHER - 3/8 STD	1
16	NUT, 7/16-14, NYLON LOCK	1
17	WASHER, #8, SPLIT LOCK	2
18	KEY, SQUARE, 1/4 X 1	2
19	RETAINING RING, EXTERNAL	1
20	NUT, 7/16-14, SERR. FLANGE LOCK	2
21	#8-32 x 1 1/2, Alloy, SHCS, ZP	2
22	WASHER, 1/4, SPLIT LOCK	4
23	SPROCKET, 35B10, 5/8" BORE	1
24	BRACKET, MOTOR MOUNT	1
25	GEAR MOTOR, RIGHT ANGLE	1
26	M6 x 1, X 18MM, CL 8.8, ZP	4
27	KEY, SQUARE, 3/16 X 1	1
28	SPROCKET, 35B30, 1 1/4" BORE	1
29	CHAIN ASSEMBLY, #35	1
30	5/16-18 x 3/4, SERRATED FLANGE, GR 5, ZP	4
31	SET SCREW, 5/16-18 X 1/2, KNURLED CUP GRIP	2
32	KEY, MACHINE, 1/8 X 1/4 X 1	1



Warranty Procedure

The information on the Warranty Claim Request Form must be provided with all warranty claims.

When a call is received with a warranty problem a Customer Service number (CSF #####) will be issued for that problem only and cannot be used again without prior approval. This number must be on all invoices submitted for payment and on all correspondence.

Before and after pictures of all the work performed must be supplied with each claim. If you take digital pictures, e-mail them to warranty@pioneerleveler.com. If you use a film camera forward the film to Pioneer Loading Dock Equipment, PO Box 338, Spring Hill, TN 37174, Attn: Warranty Dept.

No Claim will be considered for processing without the required information.

Pioneer's warranty policy for labor (once approved) requires a formal invoice from the customer performing the warranty. Pioneer must receive labor invoice within 30 days of warranty authorization. Upon receipt of labor invoice, a check will be processed.

Replacement Part under Warranty

Any replacement parts will be invoiced and a credit will be given when the damaged parts are returned to Pioneer. Pioneer will determine the only exception, if the parts are not to be returned. A copy of the credit memo will be sent to your billing address. If a check payment is required, the request must be in writing. The request then has to be approved by Pioneer's accounts payable department.

Replacement parts will be sent at Pioneer's discretion either UPS ground or OTR truck. Any other request for shipments will be charged to the dealer. I.e. UPS next day-FedEx, etc.

All returned parts will be issued a Return Goods Authorization Number (RGA #####). A form will be faxed to you with this number, the signed copy is to be faxed to 1-931-486-0316 or returned with the parts. The Return Authorization is only good for 30 days. **The RGA# must be listed on all returns, using the RGA form as a packing list.**

No credits will be issued without proper authorization. **No Credit will be given on non-Pioneer parts.**

A copy of the credit memo will be sent to your billing address. The credit will be given against the invoice issued for the replacement parts.

Any questions regarding Warranty or Return Authorization should be directed to Customer Service at warranty@pioneerleveler.com or 1-866-728-6195.



Warranty claim request form

The Following Information Must Be Supplied To Process Any Claim

Dealer Name: * _____

Contact Person: * _____

Pioneer Invoice Number : _____ Date Of Purchase: _____

End User Name And address:

Name: _____

Address: _____

City: _____ State: _____ Zip: _____

Product: _____

Model Number: * _____ Serial Number: * _____

Customer Complaint: *

Scope of Service Performed: * _____

Estimated Repair: Hours: * _____ \$ * _____

If multiple repairs list hours and \$ for each item.
Pioneer requires an invoice for all claims requiring a payment.

***Before And After Pictures Must Be Supplied With All Work Performed**

Purchase a disposable camera and send it to Pioneer along with the receipt.

***Required to process all warranty claims.**

NOTES

WARRANTY

PIONEER MANUFACTURING, INC. guarantees its SLR950 Series Truck Restraint to be free from defects in materials and workmanship for a period of one (1) full year from date of shipment.

A claim for breach of warranty will be honored if the product has been properly installed, maintained and operated and not damaged by abuse.

PIONEER will exchange or repair any structural component found to be defective in nature.

PIONEER MANUFACTURING, INC.. SHALL NOT BE LIABLE FOR LOSS OF USE OF ANY EQUIPMENT OR INCIDENTAL DAMAGES.

Pioneer reserves the right to make product improvement at any time without prior notice.

Warranty Phone # 1-866-728-6195

CAUTION:

Contact your PIONEER representative or the factory if a malfunction occurs which is not understood. DO NOT attempt to correct the situation without proper information and understanding, as this may damage components and void the warranty.

SERVICE AND MAINTENANCE

PIONEER recommends periodic inspection and servicing of the SLR950 Truck Restraint to assure proper operation and maximum life span of the unit. Units should be inspected a minimum of every thirty (30) days, and if needed, can be adjusted and lubricated. Contact your local PIONEER dealer to secure a complete maintenance plan.