

# SMART+™ “HP” Series Hydraulic Leveler Submittal

## “HP” SERIES HYDRAULIC DOCK LEVELER MODEL SPECIFICATIONS

MODEL	LIP*	DECK*	NOMINAL LENGTH	WIDTH	HINGE CF1045	SEAMLESS HINGE TUBE	OPERATING RANGE
HP6625,30/HP7625,30	1/2" x 16"	1/4"	6'	72"/83"	1" diameter	1 5/8" dia. O.D.	+12"-12"
HP6825,30/HP7825,30	1/2" x 16"	1/4"	8'	72"/83"	1" diameter	1 5/8" dia. O.D.	+12"-12"
HP6635,40,45	5/8" x 16"	1/4"	6'	72"	1 1/8" diameter	2" dia. O.D.	+12"-12"
HP7635,40,45	5/8" x 16"	1/4"	6'	83"	1 1/8" diameter	2" dia. O.D.	+12"-12"
HP6835,40,45	5/8" x 16"	1/4"	8'	72"	1 1/8" diameter	2" dia. O.D.	+12"-12"
HP7835,40,45	5/8" x 16"	1/4"	8'	83"	1 1/8" diameter	2" dia. O.D.	+12"-12"
HP61025,30/HP71025,30	1/2" x 16"	1/4"	10'	72"/83"	1" diameter	1 5/8" dia. O.D.	+16"-16"
HP61035,40,45	5/8" x 16"	1/4"	10'	72"	1 1/8" diameter	2" dia. O.D.	+16"-16"
HP71035,40,45	5/8" x 16"	1/4"	10'	83"	1 1/8" diameter	2" dia. O.D.	+16"-16"

### INSERT SPECIFIC JOB REQUIREMENTS FROM CHART

--	--	--	--	--	--	--	--

**STANDARD CAPACITY**

**A.N.S.I. CAPACITY**

--	--

\*Lip and deck, 55,000 lb. minimum yield steel; 5 year structural warranty.

\*\*Models with deck width of 78" (6 1/2') are available upon request.

### STANDARD FEATURES

- (2) Laminated Bumpers
- Lip 16"
- Grease Fittings
- Maintenance Strut
- Lip Keepers/Night Locks
- Fully Hydraulic Actuation
- Automatic Recycle
- Below Dock Control
- Automatic Cant Feature
- Deck Support, Structural C Channel
- In-line Safety Stop (prevents free-fall)
- Yellow & Black Diagonal Safety Stripe on Toe Guards
- Motor--1 hp. 1 ph. 60Hz
  - 115 Volt
- Full Range Toe Guards (Powder Coated Yellow)

### OPTIONAL FEATURES

- Lip 18"
- Lip 20"
- Weather Seals
- Foam Insulation
- Abrasive Deck
- Guardian Lip
- Emergency Stop
- Three Wheel Fork Lift
- Versa Panel
- 1 Phase Motor
  - 208 Volt
  - 230 Volt
- 3 Phase Motor
  - 208 Volt
  - 230 Volt
  - 460 Volt
- Hot Dip Galvanize
- SMART+™ Versa Panel
- Laminated Bumper
- Size
  - Three Sided (E-Z) Pan
  - Four Sided Pan
  - Independent Lip Control



PO Box 338 • Spring Hill, Tennessee 37174  
 931.486.2296 • 800.251.3382 • Fax: 931.486.0316  
 www.pioneerleveler.com

### JOB

Pioneer reserves the right to make product improvement at any time without prior notice.

# SMART+™ “HP” Series Hydraulic Leveler Submittal

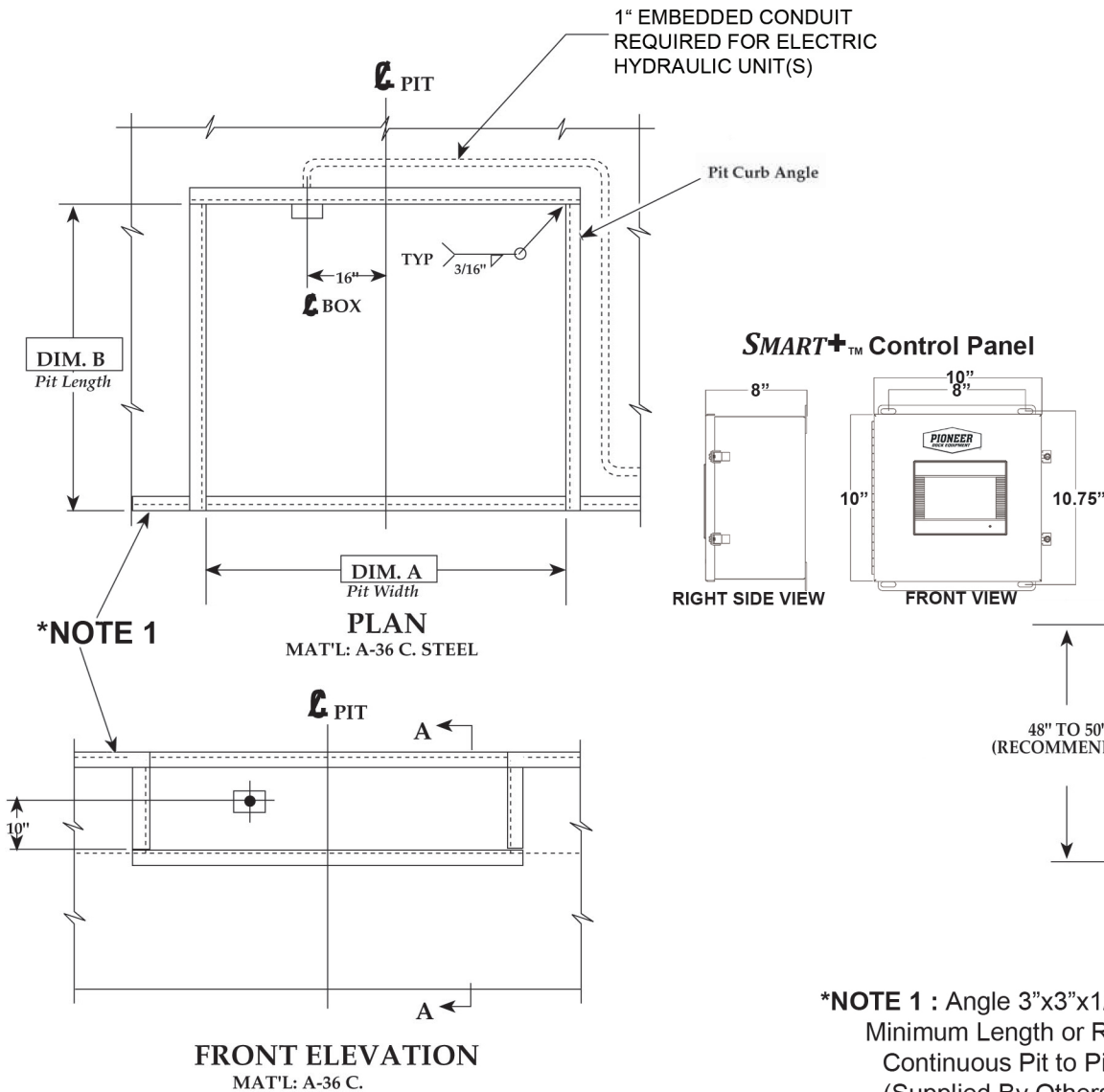

VARIABLE DIMENSIONS				
MODEL	"A"	"B"	"C"	"D"
6'W x 6'L	74"	63"	19 1/2"	20"
6'W x 8'L	74"	87"	19 1/2"	20"
6'-6"W x 6'L	80"	63"	19 1/2"	20"
6'-6"W x 8'L	80"	87"	19 1/2"	20"
7'W x 6'L	85"	63"	19 1/2"	20"
7'W x 8'L	85"	87"	19 1/2"	20"
6'W x 10'L	74"	111"	23 1/2"	24"
6'-6"W x 10'L	80"	111"	23 1/2"	24"
7'W x 10'L	85"	111"	23 1/2"	24"

INSERT SPECIFIC JOB DIMENSIONS FROM CHART

--	--	--	--	--

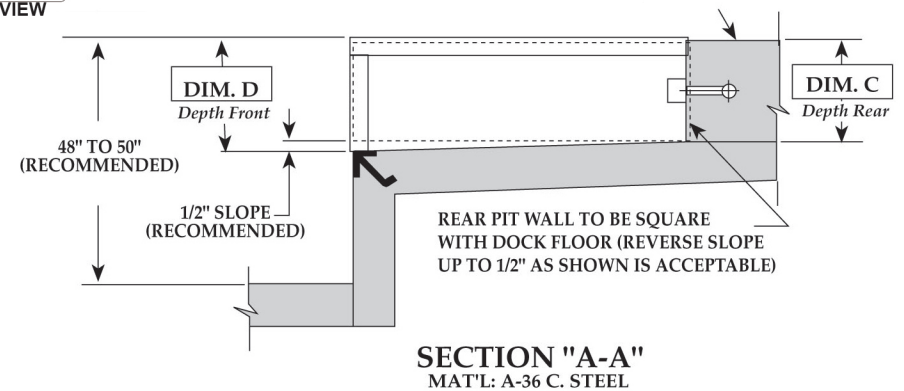

\*NOTE 1 : Angle 3"x3"x1/4"x20"  
Minimum Length or Run  
Continuous Pit to Pit.  
(Supplied By Others)

DRAWN :	SCALE: AS NOTED	DATE: 1/30/95	DRAWING NUMBER:
---------	-----------------	---------------	-----------------

TOLERANCES		
Inch Dimension = 1/16"	Decimal Dimension = .005	Angles = 1



PO Box 338 • Spring Hill, Tennessee 37174  
931.486.2296 • 800.251.3382 • Fax: 931.486.0316  
www.pioneerleveler.com

**JOB**

Pioneer reserves the right to make product improvement at any time without prior notice.