



# “C” Series Mechanical Pit Levelers



P.O. Box 338 • Spring Hill, Tennessee 37174 • 1-800-251-3382 • fax: 931-486-0316 • [www.pioneerleveler.com](http://www.pioneerleveler.com)



# **WARNING**

**DO NOT install, operate or service product unless you have read and understand the Safety Procedures, Warnings, Installation and Operating instructions contained in this manual. Failure to do so could result in serious injury and/or death.**

## Safety Procedures



**WARNING:** Read and understand all safety practices and operating instructions Before installing, operating or servicing the dock leveler. Failure to follow the safety practices and operating instructions may result in property damage, serious bodily injury and/or death.

**If you do not understand the safety procedures or the instructions, ask your supervisor to explain the safety procedures and/or teach you how to use the dock leveler.**



**CAUTION:** The installer and/or operator **MUST** be very familiar with the operation, function and various parts of the PIONEER Pit Leveler **PRIOR** to installation and/or operation. If this is not the case, it is **IMPERATIVE** that the installer and/or operator read, and fully understand, the entire contents of this manual. **Be certain to read and understand all warning and caution statements contained in this manual prior to any installation, operation or servicing of this unit.**

- 1 Do not operate this equipment while under the influence of drugs or alcohol.
- 2 Do not stand in the driveway between the dock leveler and a truck backing or pulling away.
- 3 Be sure the truck wheels are chocked, or the truck is held in place by a restraining device, before attempting to load or unload the truck.
- 4 Do not use the dock leveler if it looks broken or does not seem to work right. Lockout/tag out the defective equipment. Tell your supervisor immediately.
- 5 Do not operate the leveler with equipment, material or people on the platform and/or lip or in front of the leveler.
- 6 Be certain that equipment, material or people are not on the dock leveler before allowing a truck to pull out.
- 7 Keep clear of the dock leveler when it is moving. Never place your hands, arms, feet, or legs in the position where a moving dock leveler or a moving load could cause injury. **If in doubt, do not do it!**
- 8 If the dock leveler is not working properly, using the operation instructions in this manual, **do not use the dock leveler.** Contact your authorized PIONEER representative.
- 9 **Never attempt to work under the dock leveler, for service or repair, without proper placement of maintenance strut, safety cones and equipment around the leveler.**
- 10 Damage to the dock leveler, personal injury or death can result from abuse and/or negligent use of this equipment.
- 11 If you have any questions, or if a malfunction occurs which is not understood, ask your supervisor to contact your authorized PIONEER representative for assistance **PRIOR** to attempting any corrective measures.





***THIS IS THE SAFETY ALERT SYMBOL. IT IS USED TO ALERT YOU TO POTENTIAL PERSONAL INJURY HAZARDS. OBEY ALL SAFETY MESSAGES THAT FOLLOW THIS SYMBOL TO AVOID POSSIBLE INJURY AND/OR DEATH.***



## **WARNING**

***INDICATES A POTENTIALLY HAZARDOUS SITUATION WHICH, IF NOT AVOIDED, COULD RESULT IN SERIOUS INJURY AND/OR DEATH.***



***KEEP THIS MANUAL AND ALL SAFETY PROCEDURES IN A SECURE LOCATION WITH EASY ACCESS.***



***WARNING! READ AND UNDERSTAND THIS ENTIRE MANUAL PRIOR TO OPERATING THIS EQUIPMENT.***



***WARNING! A DOCK LEVELER CAN BE A POTENTIAL THREAT TO PERSONS AND PROPERTY, IF NOT USED PROPERLY. SAFE OPERATION IS THE RESPONSIBILITY OF THE OPERATOR.***



***WARNING! DO NOT ENTER THE AREA IN FRONT OF OR BELOW THE DOCK LEVELER. SERIOUS PERSONAL INJURY AND/OR DEATH MAY RESULT.***



***WARNING! DO NOT ATTEMPT TO INSTALL, MAKE REPAIRS OR ADJUSTMENTS. ONLY A TRAINED AND AUTHORIZED SERVICE TECHNICIAN SHOULD PERFORM REPAIRS OR ADJUSTMENTS. ONLY A QUALIFIED CONTRACTOR/SUB-CONTRACTOR SHOULD PERFORM THE INSTALLATION PROCESS. CONTACT YOUR LOCAL PIONEER DEALER FOR ASSISTANCE.***

## SECTION 1

## INSTALLATION INSTRUCTIONS RECEIVING AND HANDLING

RECEIVING:



**WARNING**

Before installing the dock leveler, read and follow the safety procedures and the operating instructions. Failure to follow the safety procedures could result in serious injury and/or death.

Check for possible damage or missing parts immediately upon receipt of unit. Note any damage on receiving papers.

Prepare any claims against carrier if necessary.

**NOTE:** Damage noticed after receipt must be reported to carrier within 15 days.

Notify Pioneer of any damage or missing parts.

HANDLING:

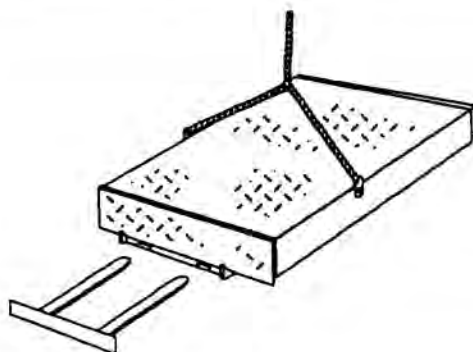

FIGURE A

Move leveler into position by using:

- chain sling inserted into side plate holes. (See Figure A)
- fork lift, inserted into front fork slots.
- fork lift, inserted into rear fork slots just below deck.

**NOTE:**

Two bumpers are shipped with each leveler and weather seals, if applicable, are strapped under leveler. Handle with care to avoid damage to these components.

## SECTION 1

## INSTALLATION INSTRUCTIONS INSTALLATION

INSTALLATION: (Consists of 3 phases)

Pit preparation

Leveler Preparation

Leveler Installation



**CAUTION:** Before you start to install the leveler, use proper safety signs and barriers to separate the work area from the remainder of the dock.



**WARNING**

Never allow anyone to stand on or near dock leveler when it is being lifted or placed into the pit. Failure to follow this warning can allow the dock leveler to fall, tip, or swing into people, resulting in serious injury and/or death.

FIGURE B - PLAN VIEW

# "C" Series Pit Detail

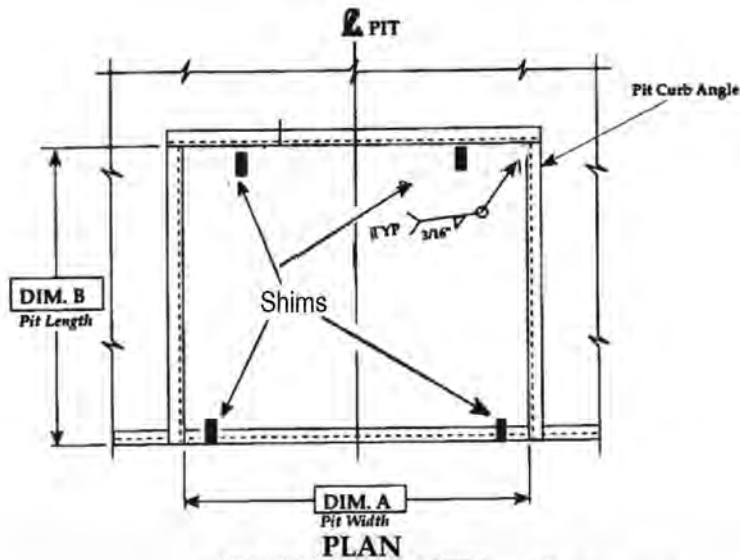

DIM. "B" MAT'L: A-36 C. STEEL

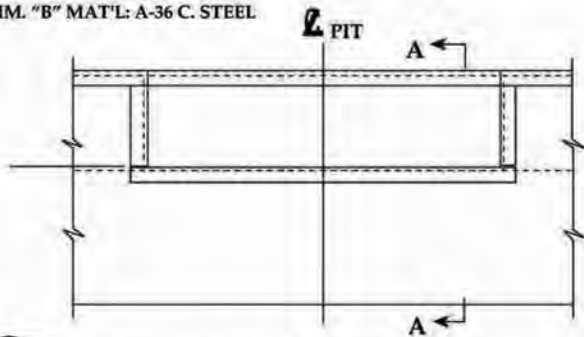

**FRONT ELEVATION**  
DIM. "B" MAT'L: A-36 C. STEEL

VARIABLE DIMENSIONS				
MODEL SIZE	"A"	"B"	"C"	"D"
6'W x 6'L	74"	63"	19 1/2"	20"
6'W x 8'L	74"	87"	19 1/2"	20"
7'W x 6'L	85"	63"	19 1/2"	20"
7'W x 8'L	85"	87"	19 1/2"	20"

INSERT SPECIFIC JOB DIMENSIONS FROM CHART

--	--	--	--	--

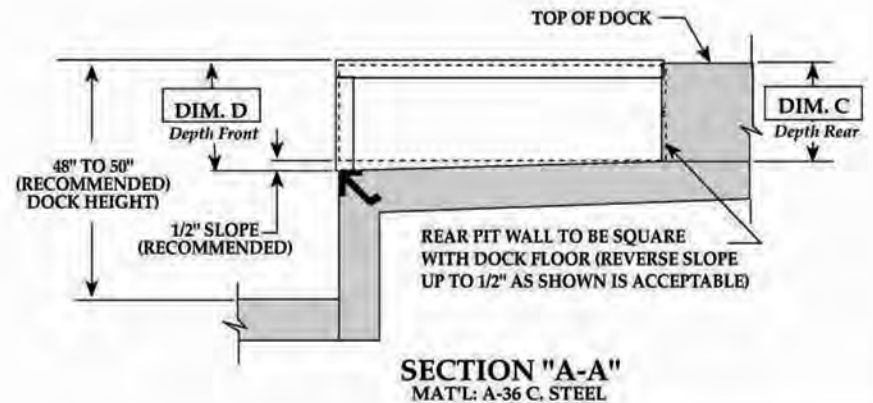

**SECTION "A-A"**  
MAT'L: A-36 C. STEEL



PO Box 338 \* Spring Hill, TN 37174  
931/486-2296 \* 800/251-3382 \* Fax: 931/486-0316  
www.pioneerleveler.com

**NOTES**

**JOB**

DRAWN:	SCALE:	DATE:	DRAWING NUMBER:
D.E.A.	AS NOTED	6/19/96	PMI-2010

TOLERANCES:		
Inch Dimension =	Decimal Dimension =	Angles =
1/16"	.005	1°

## SECTION 1

## INSTALLATION INSTRUCTIONS PIT PREPARATION

### PIT PREPARATION

1. Examine pit
2. Measure pit dimensions. (See Figure B, Page 2)



Before welding the rear frame, cover the rear weather seal with a sheet of steel to prevent setting fire to the weather seals. Failure to do so may result in property damage.

Pits walls should be square and plumb. Clean all debris from pit. Verify that walls are square and plumb.

### PRE-PLACEMENT OF SHIMS:

1. Place shims in correct locations on pit floor before lowering leveler into place in pit.

Proper shim thickness will assure that deck of leveler is level with dock floor.

#### NOTE:

Shims are to be placed directly under rear frame uprights, and under lip keepers. (See Figure C, Page 3) and (See Plan View, Page 2).

## SECTION 1

## INSTALLATION INSTRUCTIONS LEVELER PREPARATION

### LEVELER PREPARATION

1. Position leveler directly in front of pit
2. Cut restraining band on lip.

Remove band completely from leveler.

FIGURE C

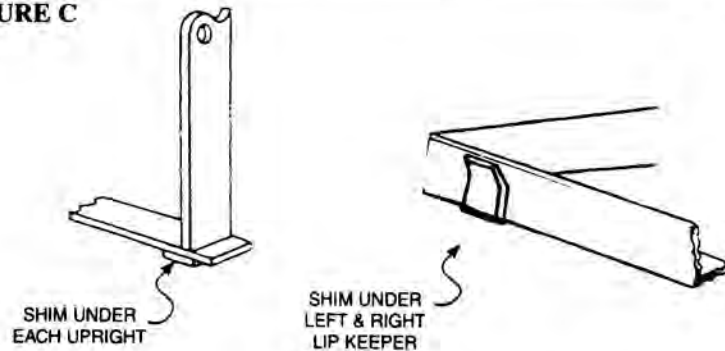
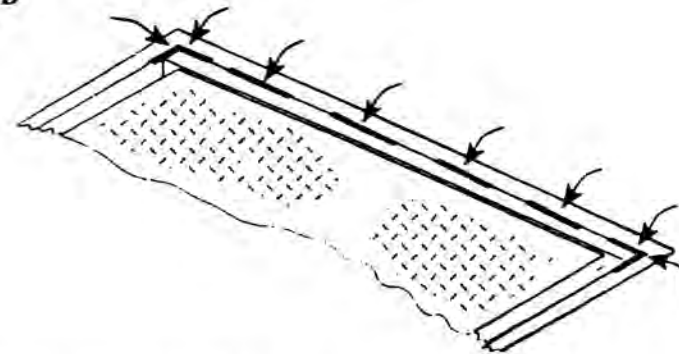

FIGURE D



**! WARNING**

Keep fingers, hands, and head away from the lip when it is released. Fingers, hands, or head could be struck by or caught between the lip and other parts of the dock leveler causing serious injury and/or death.

**! WARNING**

DO NOT work under the dock leveler, ramp, or lip unless the maintenance strut is in place.

**LEVELER INSTALLATION:**

1. Place leveler into pit opening.
2. Recheck shim packs to ensure leveler is at proper height, flush with floor level, front and rear, after restraining band has been cut.
3. Bring deck section of leveler to fully raised position.
4. Place maintenance strut securely under leveler.

**! WARNING**

Improper installation of anchoring devices or installation into aged or unsound concrete could result in serious injury and/or death.

Allow one inch (1") equal clearance between leveler sides and pit walls. Rear frame angle of leveler should be tight against and flush with rear curb angle for proper welding.

Shims must be placed properly under each rear frame upright, and front lip keepers. (See Figure C, Page 3, for close up view and Plan View B, Page 2, for shim locations.)

Skip weld rear of leveler to curb angle (weld center first then ends) and front shims to leveler and curb angle. (See Figure D, Page 3 & Figure C, Page 3)

To operate, pull **and hold** the ratchet release chain located at rear of leveler.

**! WARNING**

Be Careful of the lip falling before the lip lock is engaged. The lip plate could fall causing serious injury and/or death.

Place strut in tubes located on base & under lip.



**SECTION 1****INSTALLATION INSTRUCTIONS  
LEVELER INSTALLATION**

<b>LEVELER INSTALLATION:</b>  5. Weld all shims securely in place.	Front shims must be welded securely to frame and steel curb angle. Rear shims must be welded securely to the rear base frame.
6. Store maintenance strut.	
7. Walk forward onto leveler, returning it to dock level with lip in keepers.	
8. Install bumpers on dock face.	Securely bolt bumpers to dock face as close to pit opening as possible. Bumpers should be flush with dock floor or 48" off ground. Raised bumpers should be supported to floor from behind.
9. Complete weld at rear of leveler.	Weld to cover approximately 50% of the length of the rear angle. Ensure welds are placed directly behind frame uprights and at ends of angle. (See Figure D, Page 3)

**CAUTION:** Before you start to install the leveler, use proper safety signs and barriers to separate the work area from the remainder of the dock.

**20" LIP KEEPER INSTALLATION INSTRUCTIONS**

Two separate lip keeper angles are provided with every unit that has a 20" lip. These angles are tack welded to the leveler base frame just behind the lip.

Break each one loose and set the leveler into the pit per the installation instructions in the owner's manual.

Prior to angle installation or shimming make sure that the unit is snug against the embedded curb angle at the back of the pit.

Place the lip keepers under the front base angle on either side of the unit with the top of the angle protruding out past the base 1/4" in the front and on the left for the left hand keeper and on the right for the right hand keeper. This will facilitate welding.

Fully weld the keeper angle to the base angle.

Proceed with shimming per the owner's manual.

**Figure E**

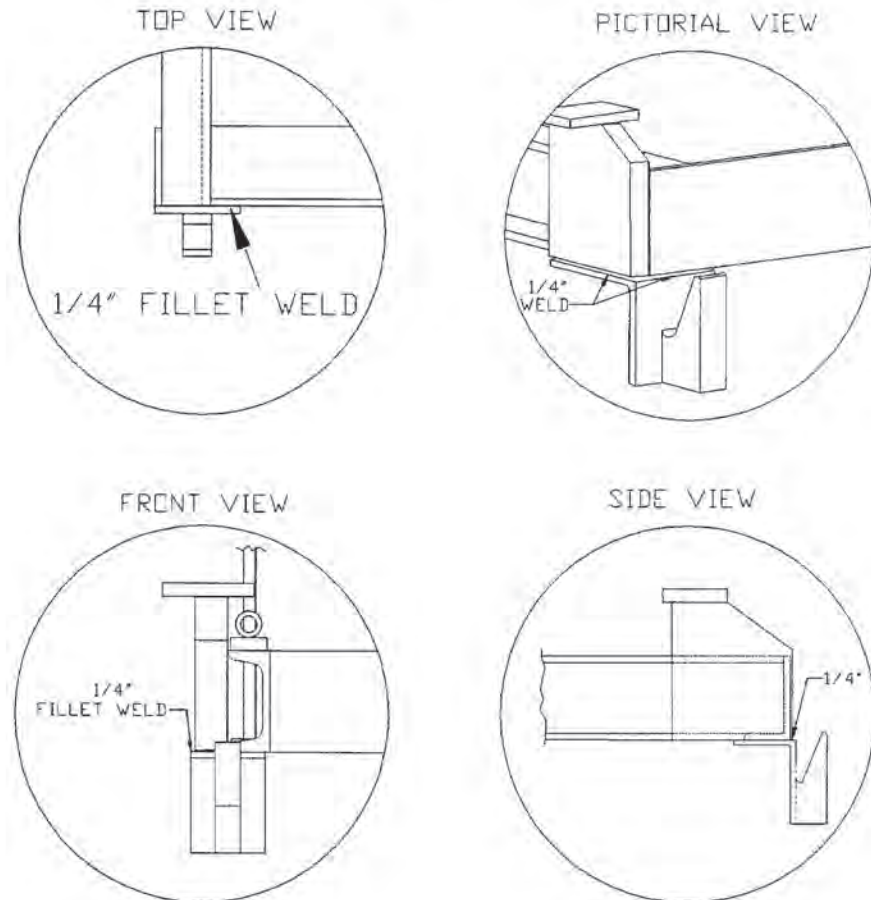

**! WARNING**

**ALWAYS** secure the vehicle with a vehicle restraint or wheel chocks before operating the dock leveler.

- \* **DO NOT** operate leveler with anyone standing on or in front of leveler.
- \* **DO NOT** lift the leveler by hand.
- \* **ALWAYS** keep fingers, hands, feet, and head clear of all moving parts.

**! WARNING**

If the lip does not fully extend, do not lift by hand. Restore leveler to dock level and try again. If lip still does not fully extend, the dock leveler requires maintenance or adjustment. Notify your supervisor. **DO NOT** use the leveler until it has been repaired. Failure to do so could result in serious injury and/or death.

**! WARNING**

If the lip does not fall to the stored position, the dock leveler requires maintenance or adjustment. Notify your supervisor. **DO NOT** use dock leveler until it has been repaired. Failure to do so could result in serious injury and/or death.

**ABOVE DOCK USE:**

1. Pull firmly **and hold** the release ring located in rear of deck.

When deck raises and lip extends, release the ring. **DO NOT** release the ring until the lip is fully extended.

2. Walk forward onto deck to lower unit onto truck bed. (Truck should be secured firmly against bumpers with "Truck Restraint" or wheel chocks.)

With standard locking type lip mechanism, lock will release once lip makes firm contact with truck bed.

3. When truck departs, lip will close to pendant (not stored) position.

This action applies when truck is above dock height.

4. Walk forward onto deck until unit is returned to stored position.

In this position, lip is secure in lip keepers, and ready to receive the next truck.

**ABOVE DOCK USE:**

5. Leveler may be recycled with truck at dock.

Pull the rear release ring in short, rapid pulls allowing deck to raise 6" - 8" above dock with lip down.

Walk forward on to leveler, returning it to dock level with lip in keepers.

This allows operator to close the truck and/or building door prior to truck departure.



**SECTION 2****OPERATING INSTRUCTIONS  
BELOW DOCK OPERATION****BELOW DOCK USE: (WITH LIP EXTENDED)**

- |  |  |
|--|--|
| 1. Repeat steps 1 & 2 for above dock use.  |  |
| 2. As you walk forward on the leveler, pull the safety leg release ring located in the front of deck plate. (Toward the Lip) | This will pull safety legs away from the pads they would normally contact allowing unit to go below dock.<br><br>When lip makes firm contact with the truck bed, release the front ring. |
| 3. When truck departs, lip will return to pendant (not stored) position.   | Lip will be in front of lip keepers, and deck will remain below floor level.   |
| 4. To recycle unit after truck departure, pull release ring in short, rapid pulls.   | This action will allow the deck to raise 2" – 3" above dock floor while the lip will remain in a pendant position.   |
| 5. Leveler may be recycled with <b>truck at dock</b> .   | Follow Step #4 to recycle.   |
| 6. Following Step #4, walk forward onto deck until unit is returned to stored position.                                      | Lip should be completely closed and resting in lip keepers which provide overnight security.   |

## SECTION 2

## OPERATING INSTRUCTIONS BELOW DOCK OPERATION

### BELOW DOCK USE: (LIP RETRACTED FOR END LOADS)

BELOW DOCK CONTROL OPTION IS RECOMMENDED FOR THIS OPERATION:

1. Pull release ring in short rapid pulls.

Allow deck to raise 2" – 3" above dock floor. (This will raise lip out of lip keepers, without extending lip.)

2. As you walk forward on the leveler, pull the safety leg release ring located in the front of deck plate.

With Below Dock Control option, lip will be pushed out in front of keepers while safety legs are being pulled away from pads.

3. When truck departs, lip will close to pendant (not stored) position.

Lip will be in front of keepers, and deck will remain below dock.

4. To recycle unit after truck departs, pull release ring in short, rapid pulls.

Continue this until unit is 6" - 8" above dock floor.

5. Leveler may be recycled with truck at dock.

Follow Step #4 to recycle.

6. Following Step #4, walk forward onto deck until unit is returned to stored position.

Lip should be completely closed and resting in lip keepers which also provide overnight security.



**CAUTION: ALWAYS SECURE LEVELER WITH LIP IN KEEPERS AND SAFETY LEGS FORWARD TO INSURE SAFE CROSS TRAFFIC USE.**

ALL "C" SERIES LEVELERS ARE TESTED AND ADJUSTED AT THE FACTORY. HOWEVER, MINOR ADJUSTMENTS TO THE MAIN SPRINGS MAY BE REQUIRED ONCE THE UNIT IS INSTALLED. (UNITS WITH WEATHER SEALS NORMALLY REQUIRE MAIN SPRING ADJUSTMENT TO INSURE PROPER LIP EXTENSION). SPRING ADJUSTMENTS ARE CONSIDERED NORMAL MAINTENANCE AND ARE NOT COVERED UNDER WARRANTY.

**NOTE:** If this dock leveler was equipped with Pioneer's hydra-lip feature instead of a locking lip, it utilizes an adjustable lip control damper. It has been adjusted at the factory for optimal lip control operation. It can be further adjusted if faster or slower lip fall speeds are required.

**IMPORTANT:** Do **NOT** adjust the damper to a setting that causes the lip to close too slowly or not close at all. This could result in unfavorable operation and/or damage to the equipment!

### **WARNING**

Read and follow the safety procedures in this manual before doing any service or repair to the dock leveler. **ALWAYS SECURE LEVELER WITH MAINTENANCE STRUT BEFORE CLIMBING INTO THE DOCK LEVELER PIT OR DOING ANY MAINTENANCE OR REPAIR UNDER THE DOCK LEVELER.** Failure to do so could result in serious injury and/or death.

SYMPTOM:	PROBABLE CAUSE:	CORRECTION:
When release ring is pulled, deck raises but lip does not fully extend and lock.	1. Improper main spring adjustment.	Tighten both main spring adjustment nuts one or two rotation clockwise and re-test. Item #4 (1 1/2" socket or wrench)
	2. Lip lock spring is stretched, broken, or disconnected.	Replace spring or lower spring one or two links in snubber chain. Item #16; Assem. #6, Page 15.
	3. Front base angle installation welds broken free.	Re-weld per installation instructions.
	Leveler may be servicing trucks that are above the factory set service range (8' models – 12", 6' models – 8") causing lip to impact truck during upward movement.	Minor adjustments to service range above dock may be made in the field. Consult the local Pioneer representative or call the factory for assistance.
	Lip plate closes too quickly.	Improper damper adjustment. (if equipped)
Lip plate closes too slowly.	Improper damper adjustment. (if equipped)	Loosen damper adjustment one notch counter-clockwise and re-test.



**CAUTION:**

Contact your Pioneer representative or the factory if a malfunction occurs which is not understood. DO NOT attempt to correct the situation without proper information and understanding, as this may damage components and void the warranty.

 **WARNING**

BEFORE SERVICING THE DOCK LEVELER, READ AND FOLLOW ALL SAFETY PROCEDURES IN THIS MANUAL. FAILURE TO DO SO COULD RESULT IN SERIOUS INJURY AND/OR DEATH.

 **WARNING**

BEFORE SERVICING THE DOCK LEVELER, ALWAYS POSITION TRAFFIC CONES OR A BARRICADE BEHIND THE DOCK LEVELER. ALSO POSITION CONES OR BARRICADES IN FRONT OF THE LEVELER TO WARN AGAINST VEHICLE TRAFFIC.

- \* ALWAYS NOTIFY A FOREMAN OR SUPERVISOR THAT YOU ARE WORKING UNDER THE EQUIPMENT.
- \* ALWAYS MAKE SURE THAT THE MAINTENANCE STRUT IS IN POSITION BEFORE WORKING UNDER THE LEVELER.
- \* ALWAYS MAKE SURE THAT THE OVERHEAD DOOR IS SECURELY HELD IN THE RAISED POSITION.

**SERVICE AND MAINTENANCE**

PIONEER recommends periodic inspection and servicing of the “C” Series mechanical leveler to assure proper operation and maximum life span of the dock leveler. Units should be inspected a minimum of every six months, and if needed, (See “TROUBLE SHOOTING”, Page 11), can be adjusted and lubricated. Contact your local PIONEER dealer to secure a complete maintenance plan.

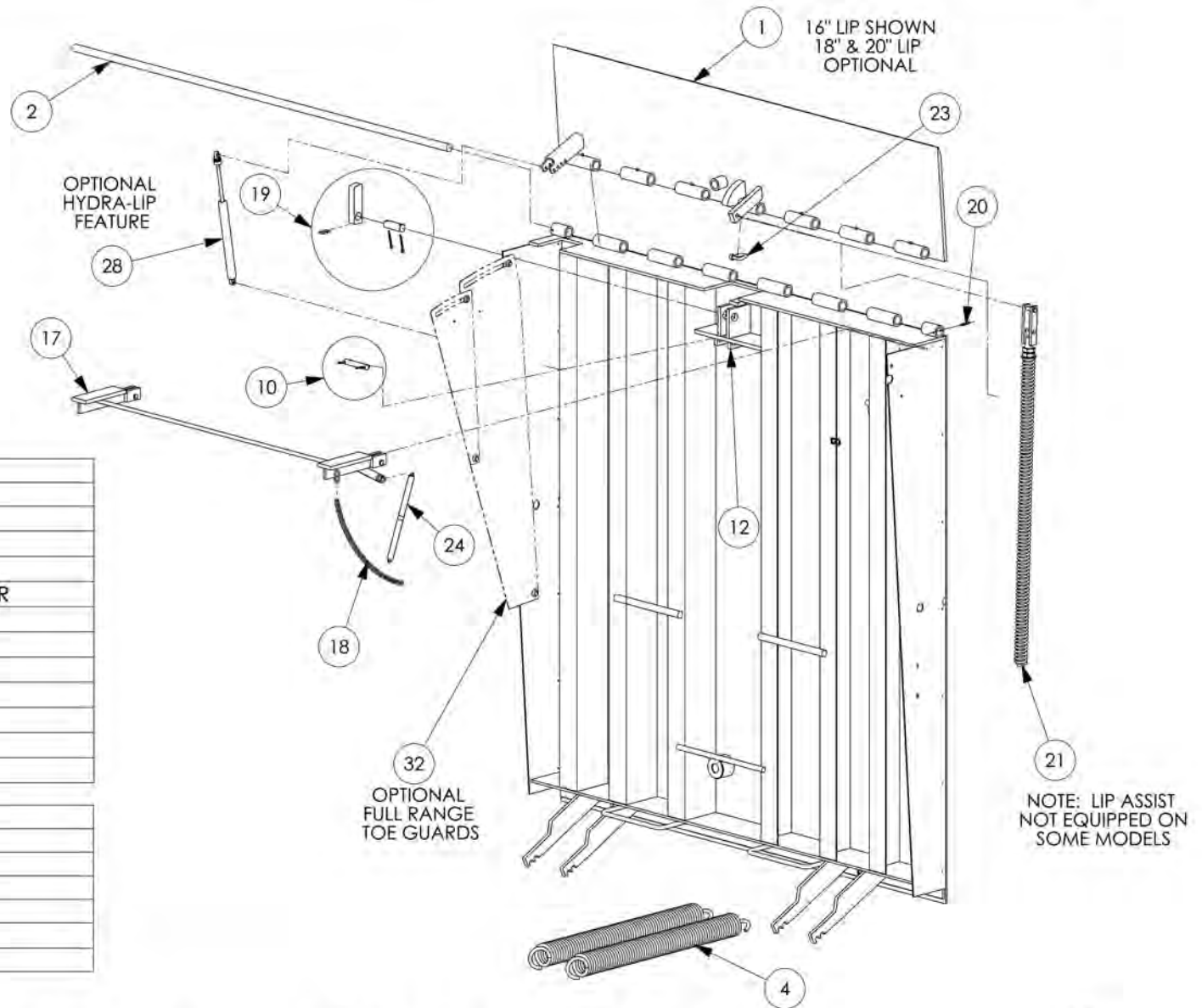

PARTS LIST	
ITEM	DESCRIPTION
1	LIP PLATE ASSEMBLY, 16"
2	HINGE PIN, LIP
4	SPRING, MAIN
10	RATCHET MOUNTING ASS'Y, UPPER
17	SAFETY LEG ASSEMBLY
18	SAFETY LEG CHAIN ASSEMBLY
19	LIP LOCK ASSEMBLY
20	ROLL PIN
23	COLD SHUT, 3/8
24	SPRING, SAFETY LEG

OPTIONAL KITS	
ITEM	DESCRIPTION
21	LIP ASSIST ASSEMBLY
28	DAMPER, LIP
32	FULL RANGE TOE GUARDS(SET)
	WEATHER SEAL KIT

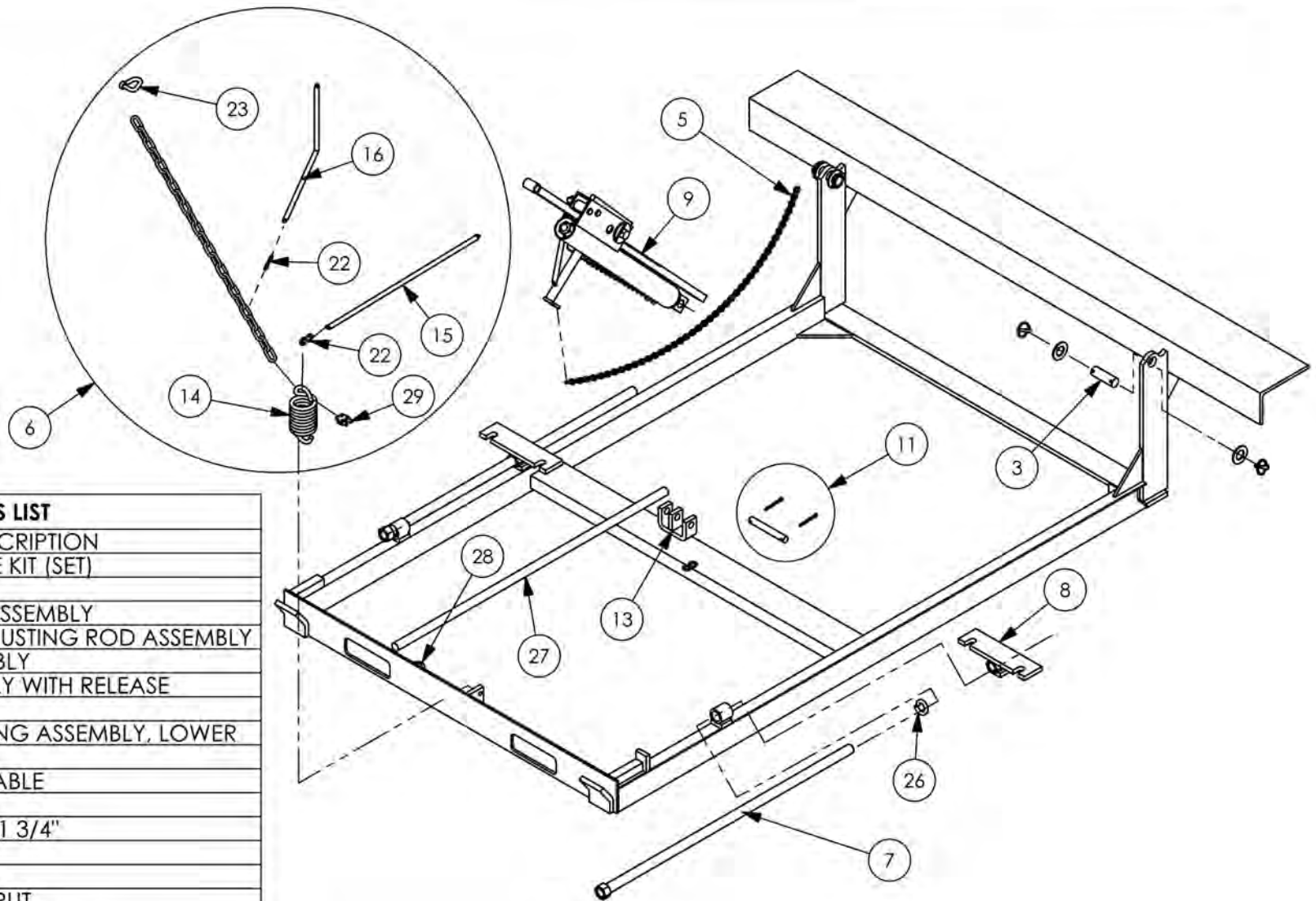

PARTS LIST	
ITEM	DESCRIPTION
3	DECK REAR HINGE KIT (SET)
5	PULL CHAIN
6	SNUBBER CHAIN ASSEMBLY
7	MAIN SPRING ADJUSTING ROD ASSEMBLY
8	WING NUT ASSEMBLY
9	RATCHET ASSEMBLY WITH RELEASE
11	LOWER PIN KIT
13	RATCHET MOUNTING ASSEMBLY, LOWER
14	SNUBBER SPRING
15	SPRING, SLACK CABLE
16	LIP LOCK SPRING
22	"S" HOOK, 3/16" X 1 3/4"
23	COLD SHUT, 3/8"
26	WASHER, 1" LOCK
27	MAINTENANCE STRUT
28	TUBE, MAINTENANCE STRUT
29	WIRE ROPE CLIP, 5/16"



## Warranty Procedure

**The information on the Warranty Claim Request Form must be provided with all warranty claims.**

When a call is received with a warranty problem a Customer Service number (CSF ####) will be issued for that problem only and cannot be used again without prior approval. This number must be on all invoices submitted for payment and on all correspondence.

Before and after pictures of all the work performed must be supplied with each claim. If you take digital pictures, e-mail them to [bobbyj@pioneerleveler.com](mailto:bobbyj@pioneerleveler.com). If you use a film camera forward the film to Pioneer Dock Equipment. PO Box 338 Spring Hill Tn 37174, Attn: Warranty Dept.

No claim will be considered for processing without the required information.

Pioneer's warranty policy for labor (once approved) requires a formal invoice from the customer performing the warranty. Pioneer must receive labor invoice within 30 days of warranty authorization. Upon receipt of labor invoice, a check will be processed.

### Replacement Part under Warranty

Any replacement parts will be invoiced and a credit will be given when the damaged parts are returned to Pioneer. Pioneer will determine the only exception, if the parts are not to be returned. A copy of the credit memo will be sent to your billing address. If a check payment is required, the request must be in writing. The request then has to be approved by Pioneer's accounts payable department.

Replacement parts will be sent at Pioneer's discretion either UPS ground or OTR truck. Any other request for shipments will be charged to the dealer. I.e. UPS next day-FedEX etc.

All returned parts will be issued a Return Goods Authorization Number (RGA #####). A form will be faxed to you with this number, the signed copy is to be faxed to 1-931-486-0316 or returned with the parts. The Return Authorization is only good for 30 days. **The RGA # must be listed on all returns, using the RGA form as a packing list.**

No credits will be issued without proper authorization. **No Credit will be given on non-Pioneer parts.**

A copy of the credit memo will be sent to your billing address. The credit will be given against the invoice issued for the replacement parts.

Any questions regarding Warranty or Return Authorization should be directed to Customer Service at [bobbyj@pioneerleveler.com](mailto:bobbyj@pioneerleveler.com) or 1-866-728-6195.





# Warranty claim request form

The Following Information Must Be Supplied To Process Any Claim

Dealer Name: \* \_\_\_\_\_

Contact Person: \* \_\_\_\_\_

Pioneer Invoice Number : \_\_\_\_\_ Date Of Purchase: \_\_\_\_\_

End User Name And address:

Name: \_\_\_\_\_

Address: \_\_\_\_\_

City: \_\_\_\_\_ State: \_\_\_\_\_ Zip: \_\_\_\_\_

Product: \_\_\_\_\_

Model Number: \* \_\_\_\_\_ Serial Number: \* \_\_\_\_\_

Customer Complaint: \*

\_\_\_\_\_

Scope of Service Performed: \*

\_\_\_\_\_

\_\_\_\_\_

Estimated Repair: Hours: \* \_\_\_\_\_ \$ \* \_\_\_\_\_

If multiple repairs list hours and \$ for each item.

Pioneer requires an invoice for all claims requiring a payment.

**\*Before And After Pictures Must Be Supplied With All Work Performed**

Purchase a disposable camera and send it to Pioneer along with the receipt.

**\*Required to process all warranty claims.**

**NOTES**

**NOTES**

## **WARRANTY**

**PIONEER Manufacturing, Inc. guarantees its "C" Series dock levelers to be free from defects in materials and workmanship for a period of one (1) year on structural assembly and main springs and one (1) year (365 days) on miscellaneous parts from date of shipment.**

**A claim for breach of warranty will be honored if the product has been properly installed, maintained and operated within its rated capacity, and not damaged by abuse.**

**PIONEER reserves the right to either repair or replace any defective parts, and will accept full responsibility for the cost of labor, materials and freight for such repairs. PIONEER's STANDARD WARRANTY PROCEDURES MUST BE FOLLOWED.**

**PIONEER MANUFACTURING, INC. SHALL NOT BE LIABLE FOR LOSS OF USE OF ANY EQUIPMENT OR INCIDENTAL DAMAGES.**

**PIONEER EXPRESSLY DISCLAIMS ANY AND ALL IMPLIED WARRANTIES.**

**All Pioneer products meet or exceed Federal Occupational Safety and Health Act Standards, Commercial Standards 202-56, and American Society of Mechanical Engineers Specifications ANSI MH14.1-84.**

**Warranty Phone # 1-866-728-6195**