

“C” Series Leveler Submittal Drawing

“C” SERIES MECHANICAL DOCK LEVELER MODEL SPECIFICATIONS

MODEL	LIP**	DECK**	NOMINAL LENGTH	WIDTH***	HINGE CF1045	SEAMLESS HINGE TUBE	OPERATING RANGE
C6625	7/16"x16"	1/4"	6'	72"	1" diameter	1 5/8" dia. O.D.	+12"-12"
C6825	7/16"x16"	1/4"	8'	72"	1" diameter	1 5/8" dia. O.D.	+12"-12"
C7625	7/16"x16"	1/4"	6'	83"	1" diameter	1 5/8" dia. O.D.	+12"-12"
C7825	7/16"x16"	1/4"	8'	83"	1" diameter	1 5/8" dia. O.D.	+12"-12"
C6630	7/16"x16"	1/4"	6'	72"	1" diameter	1 5/8" dia. O.D.	+12"-12"
C6830	7/16"x16"	1/4"	8'	72"	1" diameter	1 5/8" dia. O.D.	+12"-12"
C7630	7/16"x16"	1/4"	6'	83"	1" diameter	1 5/8" dia. O.D.	+12"-12"
C7830	7/16"x16"	1/4"	8'	83"	1" diameter	1 5/8" dia. O.D.	+12"-12"
C6635	1/2"x16"	1/4"	6'	72"	1" diameter	1 5/8" dia. O.D.	+12"-12"
C6835	1/2"x16"	1/4"	8'	72"	1" diameter	1 5/8" dia. O.D.	+12"-12"
C7635	1/2"x16"	1/4"	6'	83"	1" diameter	1 5/8" dia. O.D.	+12"-12"
C7835	1/2"x16"	1/4"	8'	83"	1" diameter	1 5/8" dia. O.D.	+12"-12"

INSERT SPECIFIC JOB REQUIREMENTS FROM CHART

--	--	--	--	--	--	--

STANDARD CAPACITY

A.N.S.I. CAPACITY

--	--

**Lip and deck, 55,000 lb. minimum yield steel

WARRANTY: 1 Year on structural members & main springs, 1 year on mechanical & misc. parts (including materials, labor & freight).

STANDARD FEATURES

- (2) Molded Bumpers
- Lip 16"
- Grease Fittings
- Working Range Toe Guards
- Dual Safety Legs
- Full Length Deck Support
- Direct Extension Spring
- Counter Balance (no moving parts)
- Lip Keepers/Night Locks
- Maintenance Strut
- Yellow & Black Diagonal Safety Stripe on Toe Guards

OPTIONAL FEATURES

- Lip 18"
- Lip 20"
- Abrasive Deck
- Foam Insulation
- Hydra Lip
- Weather Seals (side & rear)
- Below Dock Control
- Full Range Toe Guards (Powder Coat Yellow)
- Laminated Bumpers

Size



PO Box 338 • Spring Hill, Tennessee 37174
 931.486.2296 • 800.251.3382 • Fax: 931.486.0316
 www.pioneerleveler.com

JOB

Pioneer reserves the right to make product improvement at any time without prior notice.

"C" Series Pit Detail

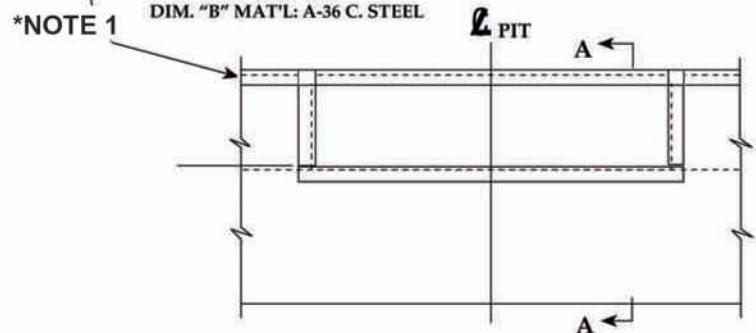
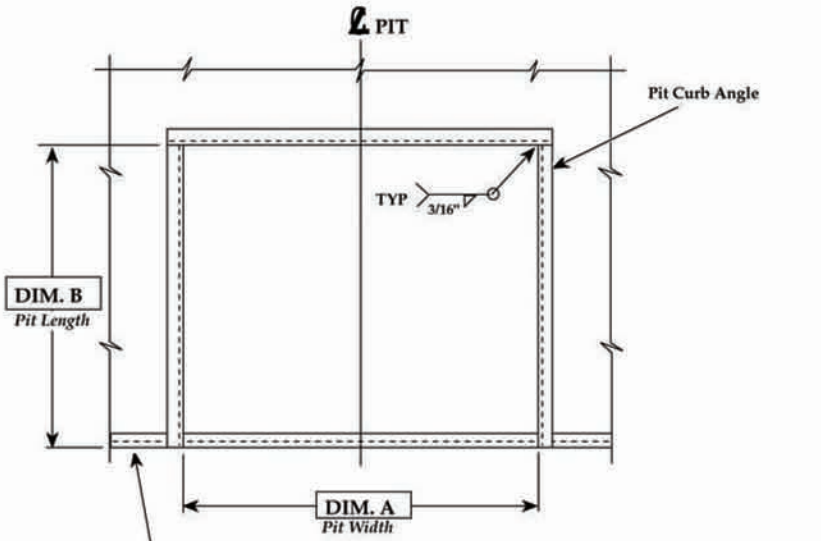

*** NOTE 1:** Angle 3"x3"x1/4"x20"
Minimum Length or Run
Continous Pit to Pit.
(Supplied By Others)

VARIABLE DIMENSIONS				
MODEL SIZE	"A"	"B"	"C"	"D"
6'W x 6'L	74"	63"	19 1/2"	20"
6'W x 8'L	74"	87"	19 1/2"	20"
7'W x 6'L	85"	63"	19 1/2"	20"
7'W x 8'L	85"	87"	19 1/2"	20"

INSERT SPECIFIC JOB DIMENSIONS FROM CHART

--	--	--	--	--

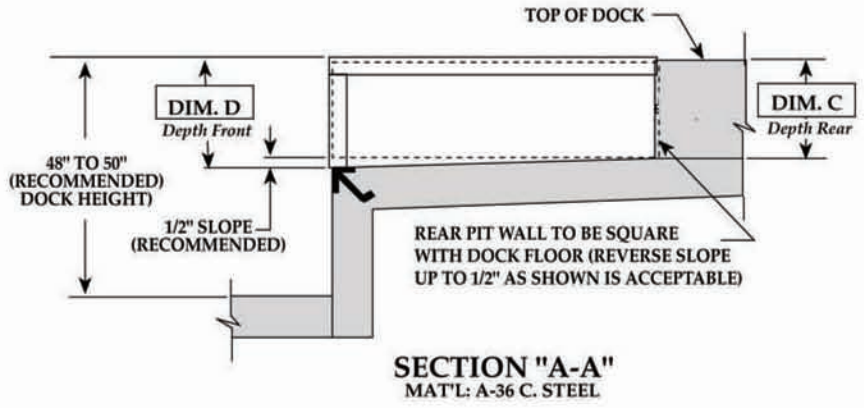

DRAWN:	SCALE:	DATE:	DRAWING NUMBER:
D.E.A.	AS NOTED	6/19/96	PMI-2010

TOLERANCES:		
Inch Dimension =	Decimal Dimension =	Angles =
1/16"	.005	1°



PO Box 338 • Spring Hill, Tennessee 37174
931.486.2296 • 800.251.3382 • Fax: 931.486.0316
www.pioneerleveler.com

JOB