

# *"HTD" Series Owner's Manual*

## *Electric - Hydraulic Top of Dock Levelers*

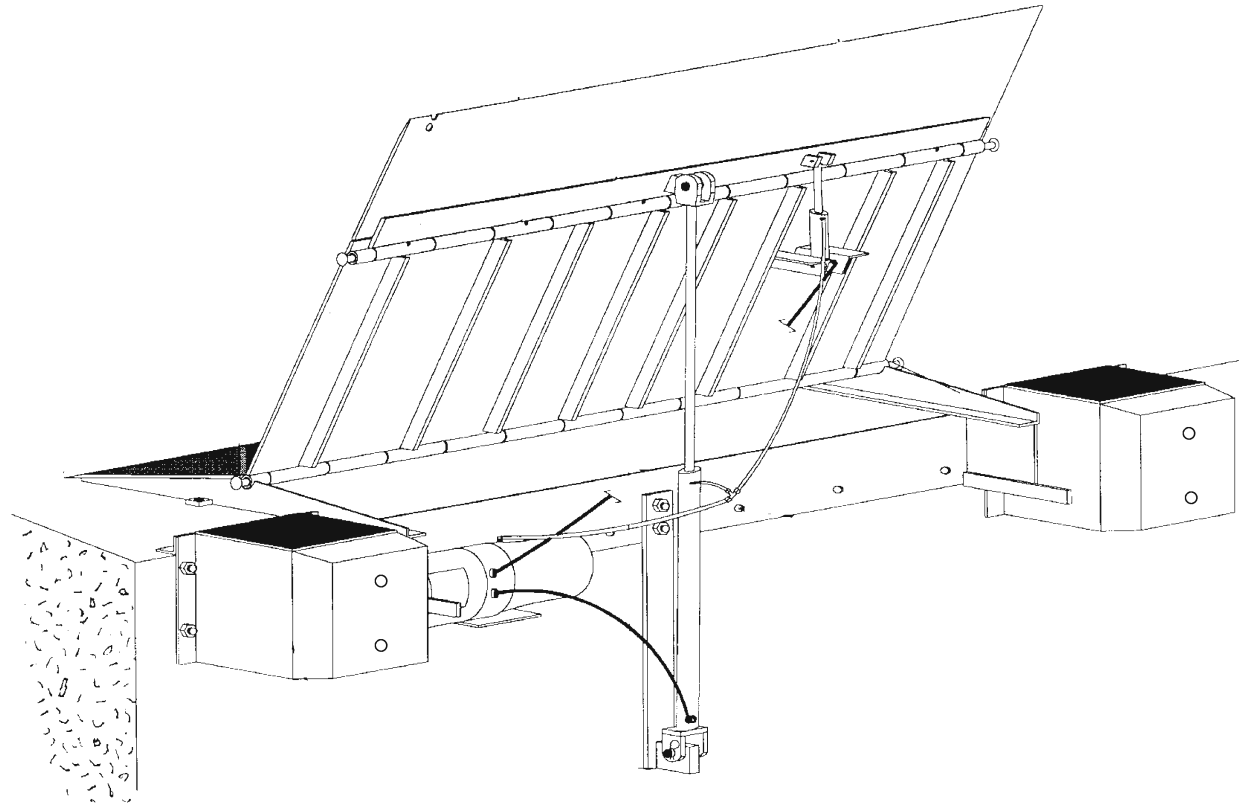

**PIONEER**  
DOCK EQUIPMENT

P.O. Box 338 • Spring Hill, Tennessee 37174  
931/486/2296 • 800/251/3382 • Fax 931/486/0316



# **WARNING**

**DO NOT install, operate or service product unless you have read and understand the Safety Procedures, Warnings, Installation and Operating instructions contained in this manual. Failure to do so could result in serious injury and/or death.**

## Safety Procedures



**WARNING:** Read and understand all safety practices and operating instructions Before installing, operating or servicing the dock leveler. Failure to follow the safety practices and operating instructions may result in property damage, serious bodily injury and/or death.

**If you do not understand the safety procedures or the instructions, ask your supervisor to explain the safety procedures and/or teach you how to use the dock leveler.**



**CAUTION:** The installer and/or operator **MUST** be very familiar with the operation, function and various parts of the PIONEER Hydraulic TOD Leveler **PRIOR** to installation and/or operation. If this is not the case, it is **IMPERATIVE** that the installer and/or operator read, and fully understand, the entire contents of this manual. **Be certain to read and understand all warning and caution statements contained in this manual prior to any installation, operation or servicing of this unit.**

- 1 Do not operate this equipment while under the influence of drugs or alcohol.
- 2 Do not stand in the driveway between the dock leveler and a truck backing or pulling away.
- 3 Be sure the truck wheels are chocked, or the truck is held in place by a restraining device, before attempting to load or unload the truck.
- 4 Do not use the dock leveler if it looks broken or does not seem to work right. Tell your supervisor immediately.
- 5 Do not operate the leveler with equipment, material or people on the platform and/or lip or in front of the leveler.
- 6 Be certain that equipment, material or people are not on the dock leveler before allowing a truck to pull out.
- 7 Keep clear of the dock leveler when it is moving. Never place your hands, arms, feet, or legs in the position where a moving dock leveler or a moving load could cause injury. **If in doubt, do not do it!**
- 8 If the dock leveler is not working properly, using the operation instructions in this manual, **do not use the dock leveler.** Contact your authorized PIONEER representative.
- 9 Never attempt to work under the dock leveler, for service or repair, without proper placement of safety bracing and dock floor barricades.
- 10 Damage to the dock leveler, personal injury or death can result from abuse and/or negligent use of this equipment.
- 11 If you have any questions, or if a malfunction occurs which is not understood, ask your supervisor to contact your authorized PIONEER representative for assistance **PRIOR** to attempting any corrective measures.



***THIS IS THE SAFETY ALERT SYMBOL. IT IS USED TO ALERT YOU TO POTENTIAL PERSONAL INJURY HAZARDS. OBEY ALL SAFETY MESSAGES THAT FOLLOW THIS SYMBOL TO AVOID POSSIBLE INJURY AND/OR DEATH.***



## **WARNING**

***INDICATES A POTENTIALLY HAZARDOUS SITUATION WHICH, IF NOT AVOIDED, COULD RESULT IN SERIOUS INJURY AND/OR DEATH.***



***KEEP THIS MANUAL AND ALL SAFETY PROCEDURES IN A SECURE LOCATION WITH EASY ACCESS.***



***WARNING! READ AND UNDERSTAND THIS ENTIRE MANUAL PRIOR TO OPERATING.***



***WARNING! A DOCK LEVELER CAN BE A POTENTIAL THREAT TO PERSONS AND PROPERTY, IF NOT USED PROPERLY. SAFE OPERATION IS THE RESPONSIBILITY OF THE OPERATOR.***



***WARNING! DO NOT ENTER THE AREA IN FRONT OF OR BELOW THE DOCK LEVELER. SERIOUS PERSONAL INJURY AND/OR DEATH MAY RESULT.***



***WARNING! DO NOT ATTEMPT TO INSTALL, MAKE REPAIRS OR ADJUSTMENTS. ONLY A TRAINED AND AUTHORIZED SERVICE TECHNICIAN SHOULD PERFORM REPAIRS OR ADJUSTMENTS. ONLY A QUALIFIED CONTRACTOR/SUB-CONTRACTOR SHOULD PERFORM THE INSTALLATION PROCESS. CONTACT YOUR LOCAL PIONEER DEALER FOR ASSISTANCE.***

## SECTION 1

## INSTALLATION INSTRUCTIONS RECEIVING AND HANDLING

RECEIVING:

### WARNING

**WARNING!** Use caution when unbanding the HTD Leveler. Keep hands clear of pinch points and wear appropriate safety attire - Glasses, Gloves, and Work Boots.

Check for possible damage or missing parts immediately upon receipt of unit. Note any damage on receiving papers.

Prepare any claims against carrier if necessary.

**NOTE: Damage noticed after receipt must be reported to carrier within 15 days.**

Notify PIONEER of any damage or missing parts.

HANDLING:

### WARNING

**WARNING!** Use caution when lifting or moving the HTD Leveler. **DO NOT ATTEMPT** to lift without suitable hoisting equipment capable of lifting as much as 1,500 lbs.

Unit is easily handled for installation by hooking a heavy chain to each buttonhead rivet.

## INSTALLATION INSTRUCTIONS INSTALLATION

GENERAL INFORMATION:

### WARNING

**DO NOT EXCEED DOCK LEVELER CAPACITY. OVER LOADING DOCK LEVELER COULD RESULT IN SERIOUS INJURY OR DEATH.**

Pioneer Top of Dock Levelers are designed to service trailers 10" above to 4" below dock level.

Prior to installation, clean the dock face and dock area.

All prepunched holes are 13/16" diameter. Use 4" to 6" x 3/4" anchor bolts.



**WARNING: Before you start to install the leveler, use proper safety signs and barriers to separate the work area from the remainder of the dock.**



1. Remove all existing bumper materials and obstructions from dock edge and sweep clean.
2. Place unit at desired location on dock surface with base plate of unit tight against dock face. Remove shipping bands from hydraulic cylinder and mounting bracket. Place bracket on anchor bolts and tighten nuts in place. (Do not attach cylinder).
3. Anchoring: use 13/16" holes in leveler as guides for drilling holes in concrete. Use 3/4" x 4.5" (min.) anchors.
  1. Extend lip forward and support safely with timber brace or other secure means.
  2. Drill and anchor two outside holes in base plate and draw unit tight to dock.
  3. Proceed to rear of unit and anchor all six bolts.
  4. Next, anchor side brackets.
  5. Complete anchoring base plate either by continuous welding to dock edge steel, or bolting all six holes.
  6. Set bump blocks in place on each side of unit and secure by welding to dock edge steel and bolting to dock if steel is less than 6" channel or angle. Anchors at rear must be welded to deck plate, cut off, and ground down to no more than 1/4" above deck surface. Tack weld all hex nuts to leveler and bumpers.

4. Install cylinder (hose entrance at bottom) on lower mounting tab then connect to top tab. Lock clevis in place with keys. Connect free end of hydraulic hose to pump fitting. Check fluid level to insure reservoir is full replace plug cap with vent cap supplied with unit.
5. Connect electrical according to prevailing codes. Standard motor: 1 h - 1ph - can be wired for 110 or 220 volts. **Call factory before re-wiring.**
6. Check operation to insure unit works correctly. Unit should raise and lip will extend. Unit may be recycled with truck in place by raising unit until lip edge clears the rear of trailer then releasing switch.

**WARNING**

All anchor bolts must be installed in accordance with the manufacturer's instruction. Improper installation may result in serious personal injury or death.

**DO NOT** install anchor bolts in cracks of expansion joints in concrete. Installation in cracks or expansion joints may cause the anchors to come loose and pull out. Use of improperly installed anchor bolts may result in serious personal injury and/or death.

**NOTE:**

All anchor bolts lengths must suit local codes and conditions. Type and depth of concrete will determine type and length of anchor bolts required.

*Illustration: 6*

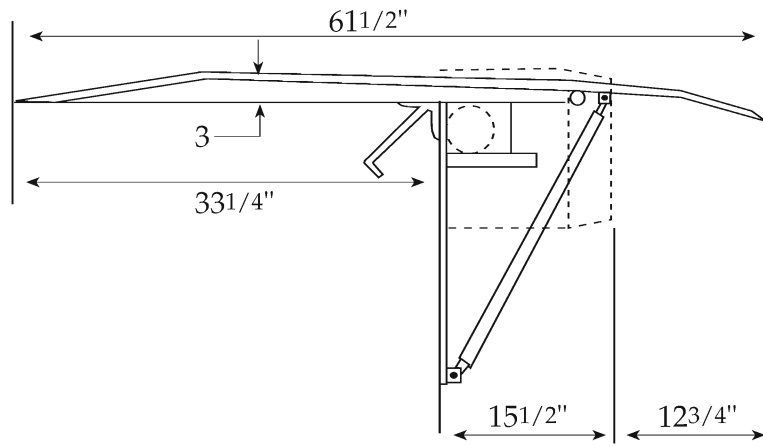

**Side View - HTD Series**

Units are shipped filled with aircraft hydraulic fluid. Check fluid level upon installation.

**IMPORTANT!** Replace plug cap with breather cap provided. **DAMAGE COULD OCCUR!**



## SECTION 1

## INSTALLATION INSTRUCTIONS ELECTRIC

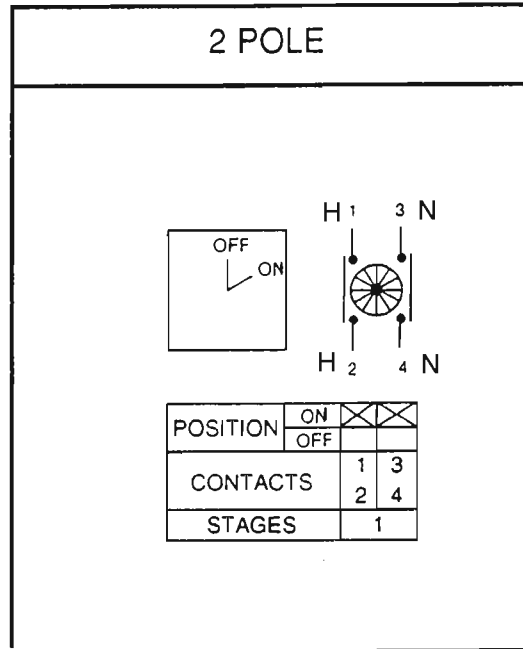

**Note:**  
Diagram represents  
Single Phase 120V ONLY

Motor may be 120V/1 phase, 240V, 1 phase or 208/240/460V 3 phase. (Please specify when ordering.)

N.E.M.A. approved switch shipped with each unit.

Install conduit and wiring as per electrical schematic instructions.

Conduit may be run externally for existing construction installation.

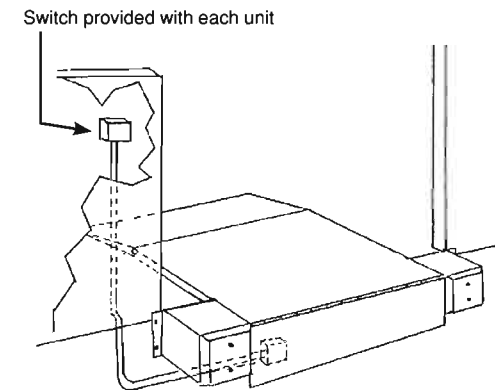

## SECTION 1

## TEST OPERATION

*Test operate unit:*

Insure breather cap is in place of plug in reservoir.

Depress button (or turn switch) to raise unit. As unit raises, lip will extend. When lip extends, release button (switch). Unit will lower to truck bed.

**ENSURE UNIT RESTS ON SUPPORT GUSSETS IN STORED POSITION. NO WEIGHT SHOULD BE RESTING ON HYDRAULIC CYLINDER SHAFT.**

HYDRAULIC FLUID CONTENT	Levelers are shipped filled with aircraft hydraulic fluid.
ELECTRICAL Motor: (Both)	1 HP, 15 minute duty cycle
Control Panel:	Wall mounted rotary box (115 volt/single phase only) standard. Meets N.E.M.A. 4X. <i>Circuit protection provided by others.</i>
Optional Control Panel (required for 3 phase or 230 volt 1 phase):	Wall mounted polymer box, with exterior reset button. Meets N.E.M.A. 4X.

MOTOR VOLTAGE (AC)	PHASE	AMP DRAW (RUNNING)	POWER (amperage) REQUIREMENT
115	1	15.0	30
230	1	7.2	20
208-220-240	3	3.6	10
440-460-480	3	1.8	10

1 HP, 1 ph motor draws 25 amps to start motor.

To avoid voltage drop, Pioneer recommends #10 wire on short runs and #8 wire on long runs. See page 7.

**Consult code requirements.**

**CAUTION: A MOTOR CAN BURN OUT FOR ANY OF THE FOLLOWING REASONS:**

1. Hook up to incorrect line voltage.
2. Single phasing of polyphase motor caused by a blown fuse or loss of one leg of electrical supply.
3. Low voltage to motor due to insufficient line capacity. This is the most common with 110V, 1 ph operation.

# Choose the Right Gauge Wire

The correct wire gauge (size) for your project is based on the amperage, or power, required and the distance the wire travels. The chart below helps you determine what gauge wire you need. Remember, the smaller the number, the larger the wire. For example, a 6-gauge wire is larger than an 8-gauge wire.

GAUGE GUIDE FOR MAXIMUM ALLOWABLE WIRE LENGTH, 2% NOMINAL VOLTAGE DROP									
		COPPER CONDUCTORS							
AMPS	WATTS	UP TO 50'	UP TO 100'	UP TO 150'	UP TO 200'	UP TO 250'	UP TO 300'	UP TO 400'	UP TO 500'
15	1800	14 Gauge	12 Gauge	10 Gauge	6 Gauge	6 Gauge	6 Gauge	4 Gauge	4 Gauge
20	2400	12 Gauge	10 Gauge	8 Gauge	6 Gauge	6 Gauge	4 Gauge	4 Gauge	2 Gauge
30	3000	10 Gauge	8 Gauge	6 Gauge	6 Gauge	4 Gauge	4 Gauge	2 Gauge	2 Gauge
40	4800	8 Gauge	6 Gauge	4 Gauge	4 Gauge	2 Gauge	2 Gauge	1 Gauge	1/0 Gauge
50	6000	6 Gauge	6 Gauge	4 Gauge	4 Gauge	2 Gauge	1 Gauge	1/0 Gauge	2/0 Gauge

This information is provided as a general guideline only. For safe wiring practices consult the National Electric Code, local building codes and regulations, and your local building inspector. Always remember that installation of electrical wire can be hazardous and, if done improperly, can result in personal injury or property damage.

Canadian codes differ from the above charts. Check your provincial codes before completing your project

## Section 2

## MAINTENANCE

### WEEKLY MAINTENANCE

**CAUTION:**  
**ALWAYS BRACE LEVELER SECURELY  
AND SAFELY WHEN MAINTENANCE IS  
REQUIRED.**

Check unit for leaks.

Check unit for physical damage.  
-Cracks in tubes and welds

Check installation

### MONTHLY MAINTENANCE

Check fluid levels

### YEARLY MAINTENANCE

Lubricate hinges and all other moving parts.

Check rubber bumpers.

### 5 YEAR MAINTENANCE

Replace hydraulic fluid.

**HYDRAULIC FLUID:**

Use aircraft fluid or Dextron III for normal operation.

For extremely cold regions fluid can be replaced by an arctic grade (or aircraft) hydraulic fluid. Check local distributors for availability.

 **WARNING**

**WARNING! DO NOT** allow lip and ramp to fall free. Allowing dock leveler to fall free could result in dock leveler coming free from dock or damaging tabs resulting in property damage, serious injury and/or death.

# HTD Series Hydraulic Top-Of-Dock

Illus#	Part#	Part Description
1	375	Lip Plate Assy. (HTD72H)
2	189	Lip Hinge Pin
3	188	Rivet ( 4 ea req)
4	378	Deck Plate Assy. (HTD72)
4	379	Deck Plate Assy. (HTD72H)
5	189	Deck Hinge Pin
18	311	Lip Stop Bar
20	9243	Molded Cord Bumper - (2 hole)
		4" x 10" x 12"
20	137	Molded Cord Bumper - (4 hole)
		4" x 12" x 13"
20	500	Molded Cord Bumper - 4" x 10" x 18"
21	2159D	Bump Block Steel w/ Cover (2 hole)
21	309	Bump Block Steel w/ Cover (4 hole)
21	899	18" Bump Block Steel w/ Cover
22	2159	10" Bump Block Assy. (2 hole)
22	310	12" Bump Block Assy. (4 hole)
22	397	18" Bump Block Assy.
23	9915	Motor Pump & Resv. -
		1 hp, 1 ph ( 1 hp)
23	9916	Motor Pump & Resv. -
		1 hp, 3 ph ( 1 hp)
24	243	Motor Mounting Plate
25	256	Motor Mounting Bolt Assy. (4 ea. Req.)

Illus#	Part#	Part Description
26	281	Hydraulic Cylinder - Deck
27	285	Reducer Fitting
28	280	Cylinder Mounting Assy.
29	282	Breather Fitting
30	283	Hydraulic Hose - Deck Cylinder
31	284	Elbow Fitting
33	A51	Deck Cylinder Mounting Pins (set of 2)
39	****	Control Box
40	9231	Lip Cylinder
41	2183	Lip Cylinder Upper Mounting Bolt
		(3/8" x 3 1/4")
42	2184	Lip Cylinder Lower Mounting Bolt
		(3/8" x 4 5/8")
43	9227	Lip Cylinder Lower Elbow Fitting
		(Pressure Side)
44	9267	Lip Cylinder Upper Elbow Fitting
		(Return Line)
45	9357	Lip Cylinder Return Line (Clear)
46	546	Lip Cylinder Hose
47	245	Lip Cylinder Mounting Tab (2 req)
48	244	Lip Cylinder Mounting Angle (2 req)

# HTD Hydraulic Top-Of-Dock Exploded View

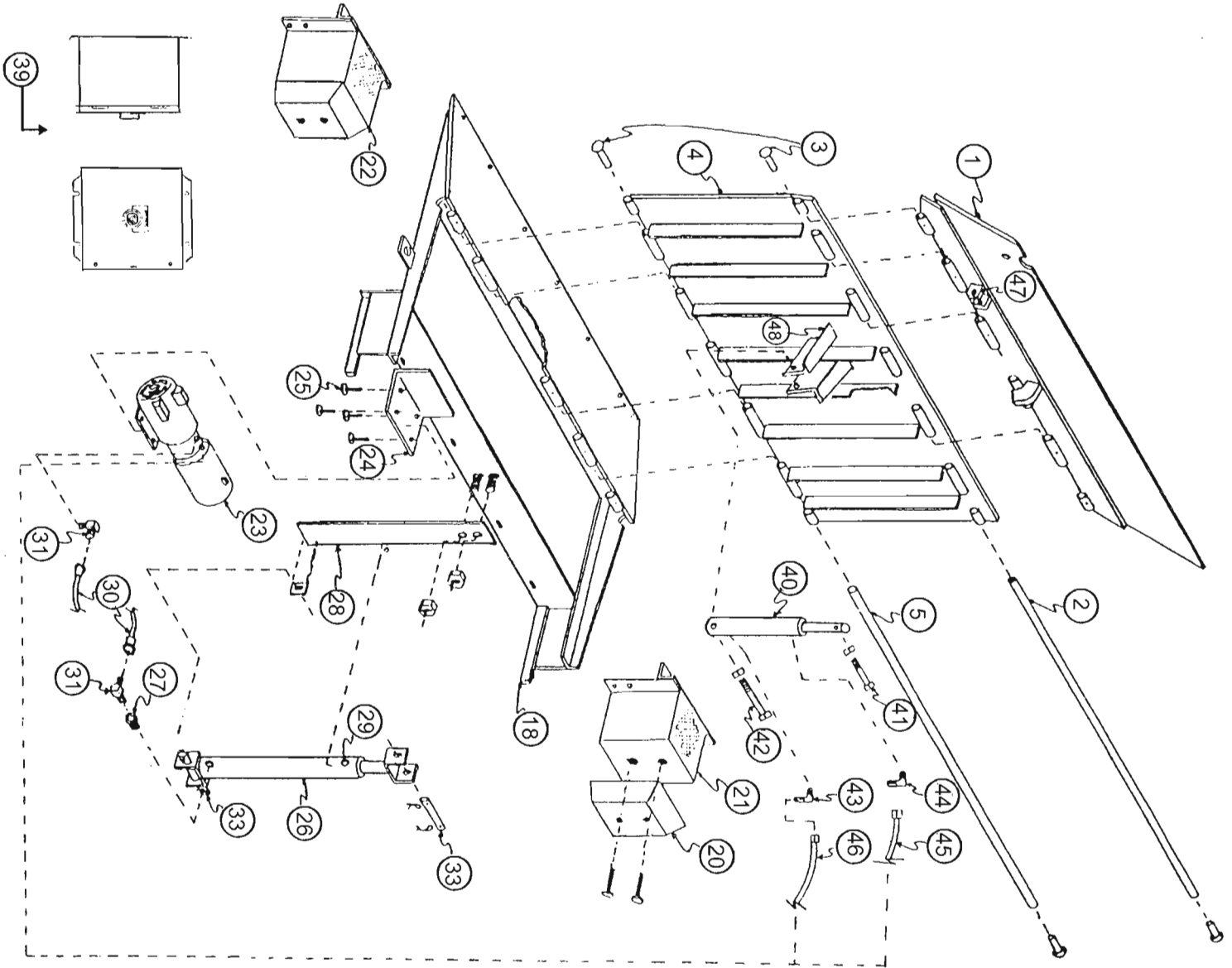

## Section 3

## OPERATING INSTRUCTIONS

Step 1	<p>With leveler in stored position, back truck into position against the bumpers.</p> <p>CAUTION: ALWAYS CHOCK TRUCK WHEELS AND/OR ENGAGE TRAILER RESTRAINT BEFORE LOADING AND UNLOADING.</p>
Step 2	<p>Remove end load, if any, from truck with leveler in stored position.</p>
Step 3	<p>Raise leveler by applying pressure to (turning) the wall mounted switch.</p> <p>Release button (switch) when both sections of leveler are fully raised. Unit will automatically lower to truck floor.</p> <p>When truck departs, unit will return to stored position.</p>
Step 4	<p>Unit may be recycled with truck in position against the bumpers.</p> <ol style="list-style-type: none"><li>1. Apply pressure to (turn) the wall switch. Center plate section of unit will raise off the truck floor.</li><li>2. Release the button (switch) as soon as the leading edge of the lip plate section clears the rear edge of the truck. The unit will tuck itself and return to the stored position.</li></ol>

**Section 4****TROUBLESHOOTING**

Lip not returning to stored position	<ol style="list-style-type: none"><li>1. Check for debris, lubricate if needed.</li><li>2. Visually check lip cylinder for damage.</li></ol>
Unit not descending.	<ol style="list-style-type: none"><li>1. Check pullover chain/spring to ensure they are connected.</li><li>2. Shuttle valve not properly adjusted.</li></ol>
Unit descending too slowly or quickly.	<ol style="list-style-type: none"><li>1. Adjust descend valve<ul style="list-style-type: none"><li>• clockwise slows descent</li><li>• counter clockwise accelerates descent</li></ul></li></ol>
Unit not raising (motor running)	<ol style="list-style-type: none"><li>1. Visual check of hydraulic fluid tank. Should be 1/2 to 3/4 full.</li><li>2. Viscosity of fluid has failed.<ul style="list-style-type: none"><li>• Change to an arctic temperature type to prevent motor/pump burnout.</li></ul></li><li>3. Consult factory.</li></ol>
Unit not raising (motor not running)	<ol style="list-style-type: none"><li>1. Check electrical hook up - voltage, phase, and wiring.</li><li>2. Motor/pump damaged - requires replacement.</li></ol>





## Warranty Procedure

**The information on the Warranty Claim Request Form must be provided with all warranty claims.**

When a call is received with a warranty problem a Customer Service number (CSF #####) will be issued for that problem only and cannot be used again without prior approval. This number must be on all invoices submitted for payment and on all correspondence.

Before and after pictures of all the work performed must be supplied with each claim. If you take digital pictures, e-mail them to [warranty@pioneerleveler.com](mailto:warranty@pioneerleveler.com). If you use a film camera forward the film to Pioneer Dock Equipment. PO Box 338 Spring Hill Tn 37174,  
Attn: Warranty Dept.

No claim will be considered for processing without the required information.

Pioneer's warranty policy for labor requires a formal invoice from the customer performing the warranty. Once approved by Pioneer a check will be processed.

### **Replacement Part under Warranty**

Any replacement parts will be invoiced and a credit will be given when the damaged parts are returned to Pioneer. Pioneer will determine the only exception, if the parts are not to be returned. A copy of the credit memo will be sent to your billing address. If a check payment is required, the request must be in writing. The request then has to be approved by Pioneer's accounts payable department.

Replacement parts will be sent at Pioneer's discretion either UPS ground or OTR truck. Any other request for shipments will be charged to the dealer. I.e. UPS next day-FedEX etc.

All returned parts will be issued a Return Goods Authorization Number (RGA #####). A form will be faxed to you with this number, the signed copy is to be faxed to 1-931-486-0316 or returned with the parts. The Return Authorization is only good for 30 days. **The RGA # must be listed on all returns, using the RGA form as a packing list.**

No credits will be issued without proper authorization. **No Credit will be given on non-Pioneer parts.**

A copy of the credit memo will be sent to your billing address. The credit will be given against the invoice issued for the replacement parts.

Any questions regarding Warranty or Return Authorization should be directed to Customer Service at [warranty@pioneerleveler.com](mailto:warranty@pioneerleveler.com) or 1-866-728-6195.



## Warranty claim request form

The Following Information Must Be Supplied To Process Any Claim

Dealer Name: \* \_\_\_\_\_

Contact Person: \* \_\_\_\_\_

Pioneer Invoice Number : \_\_\_\_\_ Date Of Purchase: \_\_\_\_\_

End User Name And address:

Name: \_\_\_\_\_

Address: \_\_\_\_\_

City: \_\_\_\_\_ State: \_\_\_\_\_ Zip: \_\_\_\_\_

Product: \_\_\_\_\_

Model Number: \* \_\_\_\_\_ Serial Number: \* \_\_\_\_\_

Customer Complaint: \* \_\_\_\_\_

\_\_\_\_\_

Scope of Service Performed: \* \_\_\_\_\_

\_\_\_\_\_

Estimated Repair: Hours: \* \_\_\_\_\_ \$ \* \_\_\_\_\_

If multiple repairs list hours and \$ for each item.

Pioneer requires an invoice for all claims requiring a payment.

**\*Before And After Pictures Must Be Supplied With All Work Performed**  
Purchase a disposable camera and send it to Pioneer along with the receipt.

**\*Required to process all warranty claims.**







## **TOP OF DOCK WARRANTY**

**ALL PIONEER DOCK LEVELERS carry a comprehensive structural warranty. PIONEER guarantees its HYDRAULIC TOP OF DOCK LEVELERS against defects in material and workmanship for a period of TWO (2) years, beginning at Date of Shipment, 1 year parts, labor, pump and cylinders.**

**PIONEER accepts full responsibility for the cost of materials, approved labor and freight for a valid warranty claim and reserves the right to either repair or replace any defective parts.**

**A claim for breach of warranty will be honored if the product has been properly installed, maintained and operated within its capacity, and not damaged by abuse.**

**PIONEER SHALL NOT BE LIABLE FOR LOSS OF ANY EQUIPMENT OR INCIDENTAL DAMAGES. PIONEER EXPRESSLY DISCLAIMS ANY AND ALL IMPLIED WARRANTIES.**

**All PIONEER products meet or exceed Federal Occupational Safety and Health Act Standards, Commercial Standards 202-56, and American Society of Mechanical Engineers Specifications ANSI MH14.1-84.**

**Warranty Phone # 1-866-778-6195**