

“EOD” & Bar Lift Owner’s Manual

MECHANICAL LEVELERS

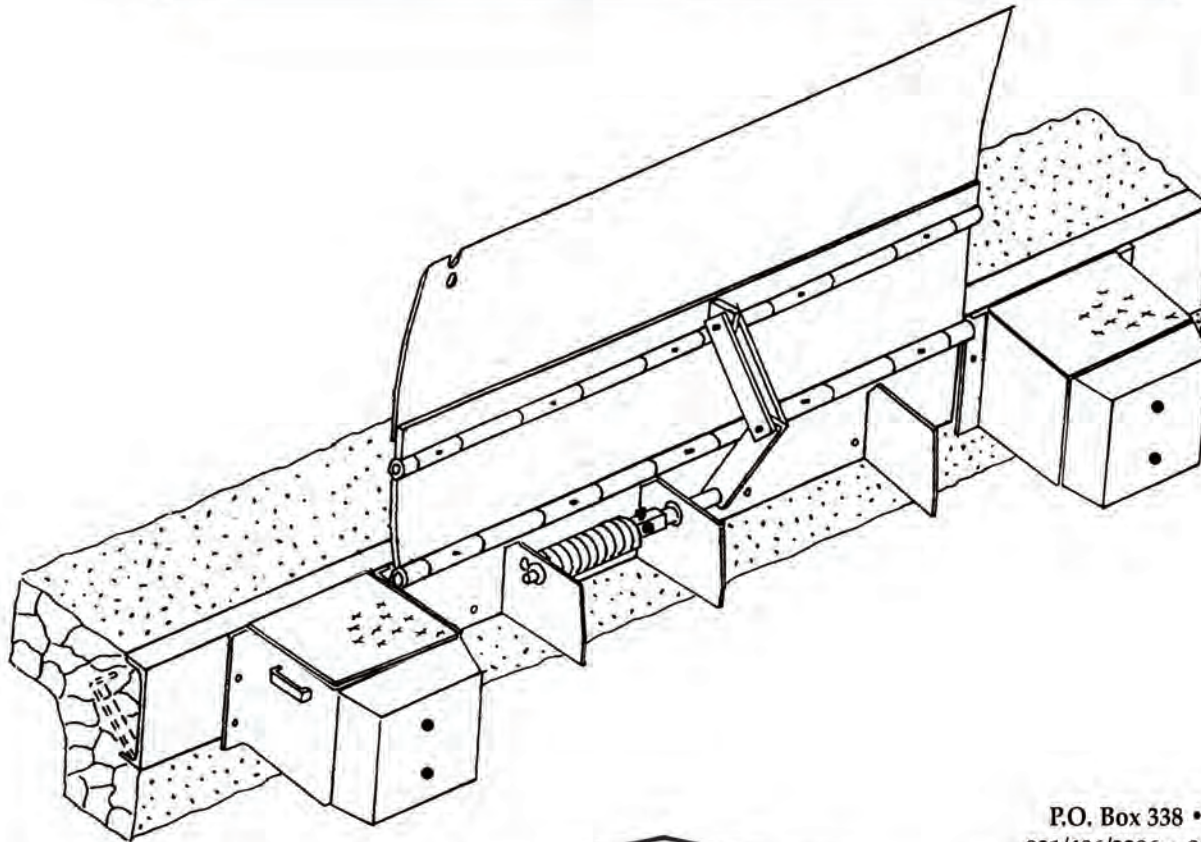

P.O. Box 338 • Spring Hill, Tennessee 37174
931/486/2296 • 800/251/3382 • Fax 931/486/0316
www.pioneerleveler.com





WARNING

DO NOT install, operate or service product unless you have read and understand the Safety Procedures, Warnings, Installation and Operating instructions contained in this manual. Failure to do so could result in serious injury and/or death.

Safety Procedures



WARNING: Read and understand all safety practices and operating instructions before installing, operating or servicing the dock leveler. Failure to follow the safety practices and operating instructions may result in property damage, serious bodily injury and/or death.

If you do not understand the safety procedures or the instructions, ask your supervisor to explain the safety procedures and/or teach you how to use the dock leveler.



CAUTION: The installer and/or operator **MUST** be very familiar with the operation, function and various parts of the PIONEER Edge of Dock Leveler **PRIOR** to installation and/or operation. If this is not the case, it is **IMPERATIVE** that the installer and/or operator read, and fully understand, the entire contents of this manual. **Be certain to read and understand all warning and caution statements contained in this manual prior to any installation, operation or servicing of this unit.**

- 1 Do not operate this equipment while under the influence of drugs or alcohol.
- 2 Do not stand in the driveway between the dock leveler and a truck backing or pulling away.
- 3 Be sure the truck wheels are chocked, or the truck is held in place by a restraining device, before attempting to load or unload the truck.
- 4 Do not use the dock leveler if it looks broken or does not seem to operate correctly. Tell your supervisor immediately.
- 5 Do not operate the leveler with equipment, material or people on the platform and/or lip or in front of the leveler.
- 6 Be certain that equipment, material and/or people are not on the dock leveler before allowing a truck to back in or pull out.
- 7 Keep clear of the dock leveler when it is moving. Never place your hands, arms, feet or legs in the position where a moving dock leveler or a moving load could cause injury. **If in doubt, do not do it!**
- 8 If the dock leveler is not working properly, using the operation instructions in this manual, **do not use the dock leveler.** Contact your authorized PIONEER representative.
- 9 Never attempt to work under the dock leveler, for service or repair, without proper placement of safety bracing.
- 10 Damage to the dock leveler, personal injury or death can result from abuse and/or negligent use of this equipment.
- 11 If you have any questions, or if a malfunction occurs which is not understood, ask your supervisor to contact your authorized PIONEER representative for assistance **PRIOR** to attempting any corrective measures.



THIS IS THE SAFETY ALERT SYMBOL. IT IS USED TO ALERT YOU TO POTENTIAL PERSONAL INJURY HAZARDS. OBEY ALL SAFETY MESSAGES THAT FOLLOW THIS SYMBOL TO AVOID POSSIBLE INJURY AND/OR DEATH.



WARNING

INDICATES A POTENTIALLY HAZARDOUS SITUATION WHICH, IF NOT AVOIDED, COULD RESULT IN SERIOUS INJURY AND/OR DEATH.



KEEP THIS MANUAL AND ALL SAFETY PROCEDURES IN A SECURE LOCATION WITH EASY ACCESS.



WARNING! READ AND UNDERSTAND THIS ENTIRE MANUAL PRIOR TO OPERATING.



WARNING! A DOCK LEVELER CAN BE A POTENTIAL THREAT TO PERSONS AND PROPERTY, IF NOT USED PROPERLY. SAFE OPERATION IS THE RESPONSIBILITY OF THE OPERATOR.



WARNING! DO NOT ENTER THE AREA IN FRONT OF OR BELOW THE DOCK LEVELER. SERIOUS PERSONAL INJURY AND/OR DEATH MAY RESULT.



WARNING! DO NOT ATTEMPT TO INSTALL, MAKE REPAIRS OR ADJUSTMENTS. ONLY A TRAINED AND AUTHORIZED SERVICE TECHNICIAN SHOULD PERFORM REPAIRS OR ADJUSTMENTS. ONLY A QUALIFIED CONTRACTOR/SUB-CONTRACTOR SHOULD PERFORM THE INSTALLATION PROCESS. CONTACT YOUR LOCAL PIONEER DEALER FOR ASSISTANCE.

SECTION 1

INSTALLATION INSTRUCTIONS RECEIVING AND HANDLING

RECEIVING:

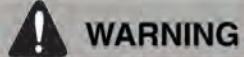

WARNING

WARNING! Use caution when unbanding the EOD Leveler. Keep hands clear of pinch points and wear appropriate safety attire - Glasses, Gloves, and Work Boots.

Check for possible damage or missing parts immediately upon receipt of unit. Note any damage on receiving papers.

Prepare any claims against carrier if necessary.

NOTE: Damage noticed after receipt must be reported to carrier within 15 days.

Notify PIONEER of any damage or missing parts.

HANDLING:

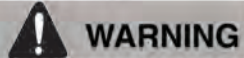

WARNING

WARNING! Use caution when lifting or moving the EOD Leveler. **DO NOT ATTEMPT** to lift without suitable hoisting equipment capable of lifting as much as 600 lbs.

Unit is easily handled for installation by hooking a heavy chain to each buttonhead rivet, (ED Series) or by hooking directly to the center plate. (BL Series)

INSTALLATION INSTRUCTIONS INSTALLATION

GENERAL INFORMATION:

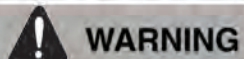

WARNING

DO NOT EXCEED DOCK LEVELER CAPACITY. OVER LOADING DOCK LEVELER COULD RESULT IN SERIOUS INJURY OR DEATH.

Edge of Dock Levelers are designed to service trailers 5" above to 5" below dock level.

The dock levelers are shipped banded without tension on spring. Adjustment should be accomplished when installed.

Prior to installation, clean the dock face and dock area.

All prepunched holes are 13/16" diameter. Use 4" to 6" x 3/4" anchor bolts.



WARNING: Before you start to install the leveler, use proper safety signs and barriers to separate the work area from the remainder of the dock.



SECTION 1

INSTALLATION INSTRUCTIONS INSTALLATION

Illustration: 1

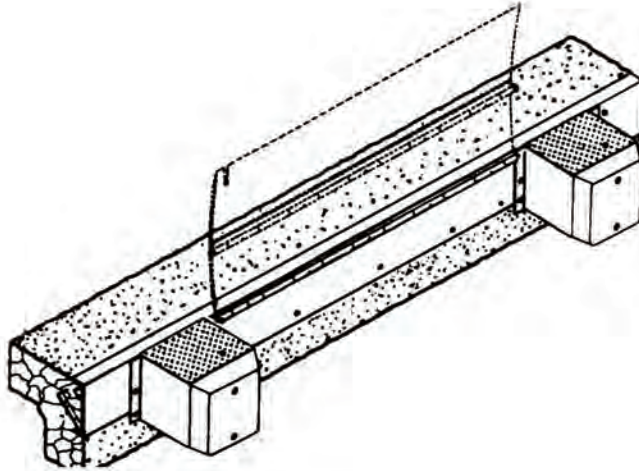

WELD ON—NEW CONSTRUCTION

Use when dock edge vertical steel is 8" or wider. At dock edge, mark the center of chosen leveler location. Mark dock edge 33" either side of center (36" for 72" models; 39" for 78" models; 42" for 84" models).

Locate leveler with top of rear hinge flush with top of dock. This will place top of base plate approx. 1/4" below dock surface.

Tack weld ends of base plate to dock face steel, the top edge of base plate being 1/4" below dock. Tack weld both bump blocks at left and right ends of leveler allowing 1/4" space for weld between base plate ends and bump block.

Continuous weld bump blocks and base plate along top and all vertical edges while holding leveler firmly against dock. Spot weld all prepunched holes along the bottom of the base plate.

Illustration: 2

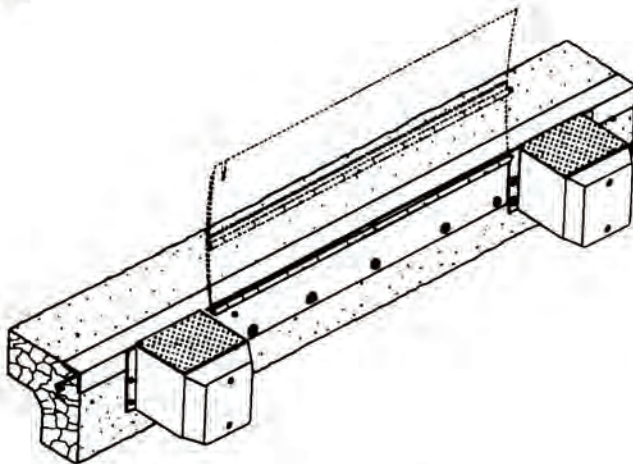

WELD ON/BOLT ON—EXISTING CONSTRUCTION

Use when dock edge steel is securely anchored, but not large enough for weld-on method.

Complete all steps of instruction under "Weld On—New Construction."

Bolt leveler and bump blocks to dock face using all 13/16" prepunched holes furnished.

Illustration: 3

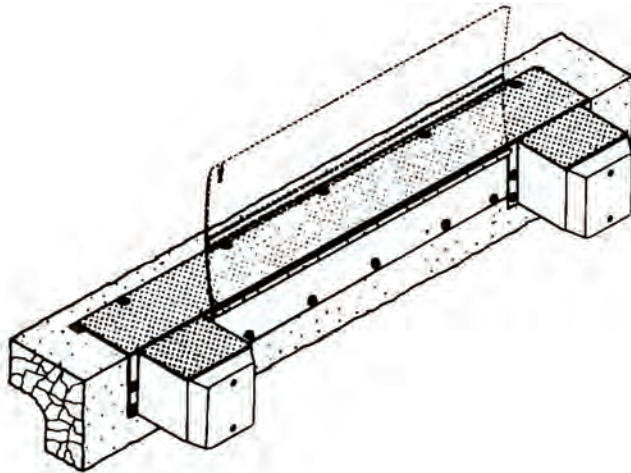

! WARNING

All anchor bolts must be installed in accordance with the manufacturer's instruction. Improper installation may result in serious personal injury or death.

DO NOT install anchor bolts in cracks of expansion joints in concrete. Installation in cracks or expansion joints may cause the anchors to come loose and pull out. Use of improperly installed anchor bolts may result in serious personal injury and/or death.

BOLT ON + APPROACH PLATE — EXISTING CONSTRUCTION

Use when dock edge has no steel, or steel is poorly anchored, and dock face is adequate for bolting. Mark and drill holes for dock leveler centered 6-1/4" below dock edge; base plate to be raised 1/8" above dock edge for welding to approach plate. Install two (2) anchor bolts in end holes, position leveler on bolts and partially tighten nuts to hold leveler secure.

Place approach plate in position on floor, front edge being 1/8" behind base plate. Mark floor along rear edge of approach plate.

Slide the plate forward 2" and cut a groove in the floor along the line previously marked. Move 2" toward the dock face and cut another groove parallel to the first (along the long dimension of the approach plate) and to the edge of the dock. Groove to be 2" wide and 1/8" deeper than the thickness of the approach plate.

If the approach plate is flat and beveled DO NOT cut a groove in the floor. Place the approach plate on the floor with the front edge flush with the dock edge.

Drill holes in floor using plate holes as guide. Install anchor bolts in plate (See General Information page 1). Weld and grind bolt heads to approach plate to a smooth dome shape. **Continuous weld** approach plate to top of base plate. Complete bolting phase of unit.

NOTE:

All anchor bolts lengths must suit local codes and conditions. Type and depth of concrete will determine type and length of anchor bolts required.

Illustration: 4

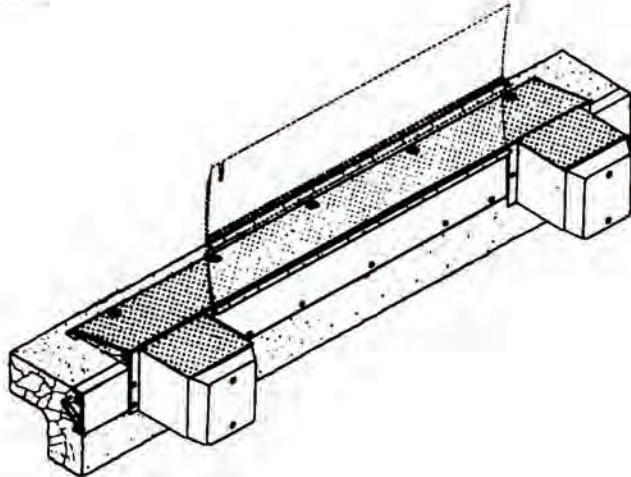
**WELD ON AND RAISE APPROACH PLATE**

Use when dock edge is sound but height is less than adequate (bolting may also be required). At dock edge, mark the center of chosen leveler location. Mark dock edge 33" either side of center (36" for 72" models; 39" for 78" models; 42" for 84" models).

Raise leveler and bump blocks to desired height (3" max.), and weld back of base plate to dock edge steel. Tack weld both bump blocks at left and right ends of leveler allowing 1/4" space for weld between base plate ends and bump block.

Cut groove in floor, position approach plate at top edge of base plate and tack weld to unit and bump blocks. (See *Illustration 3* for details.)

If the approach plate is flat and beveled DO NOT cut a groove in the floor. Place the approach plate on the floor with the front edge flush with the dock edge.

Complete bolting phase of installation, then continuous weld all points of contact between leveler, dock steel and approach plate.

Illustration: 5

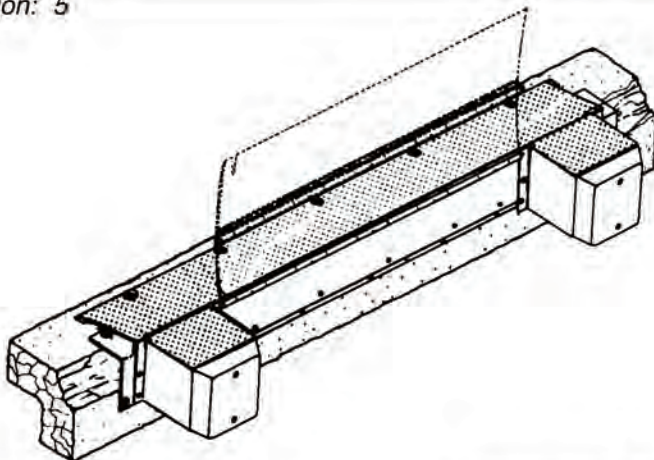
**FORMED ANGLE-WELD ON—RAISED APPROACH PLATE**

Use when dock edge is badly crumbled and dock edge is slightly low.

Unit must be raised approximately 2" in this application!

Position formed angle at desired location, mark holes, remove angle, drill holes and install angle. Install unit and approach plate according to methods described for "Existing Construction" (See *Illustrations 3 & 4*).

SECTION 1

INSTALLATION INSTRUCTIONS INSTALLATION

BARLIFT MODELS

After installation of EOD and Bumpers is completed, remove bolt from lifting bar, insert bar into bracket (handle facing forward) and reattach bolt.

SECTION 2

MAINTENANCE

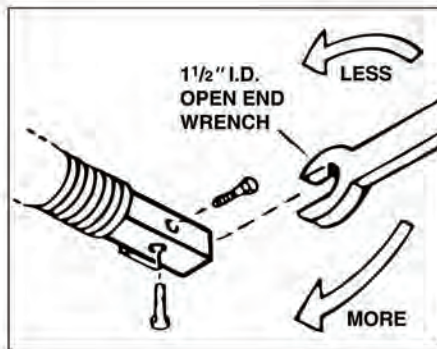

ADJUSTING TENSION ON RAMP

Units are shipped with no tension on ramp. After dock leveler is installed, adjust tension as follows:

1. Fully raise centerplate and lip plate.
2. Loosen the two set screws in spring winding assembly.
3. Place 1-1/2" wrench on square tubing and rotate tubing toward you approximately 1/4 turn. Hold tube in this position and tighten set screws.
4. Test the unit for lifting ease. Repeat steps 1 and 2 as necessary to provide easy lifting.



WARNING

WARNING! DO NOT allow lip and ramp to fall free. Allowing dock leveler to fall free could result in dock leveler coming free from dock or damaging linkage resulting in property damage, serious injury and/or death.

LUBRICATION PROCEDURE

For proper operation of your dock leveler, cleaning and lubrication should be performed every 90 days. Lubricate prior to attempting to adjust your leveler.

SECTION 3

PARTS LIST & DIAGRAM ADAPTOR KIT ASSEMBLY – ED66M

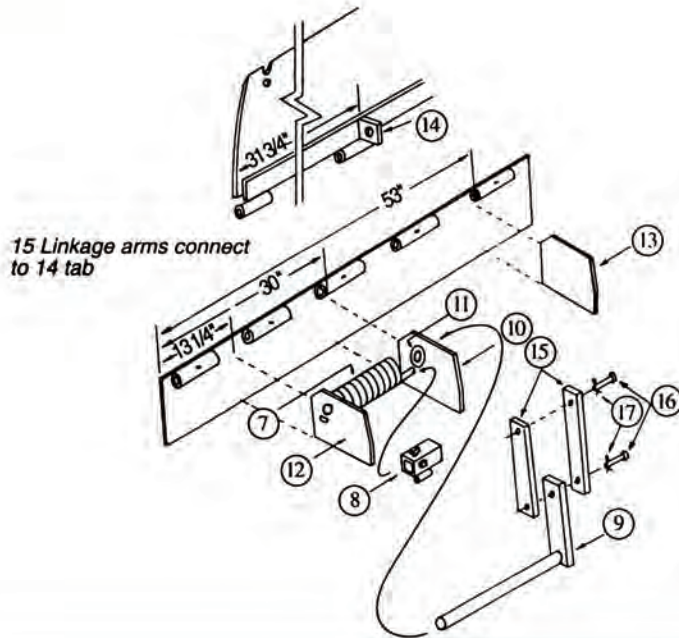

ADAPTOR KIT ASSEMBLY — ED66M

ED66M Kit, Part #192, consists of the following:

ITEM	DESCRIPTION
7	Torsion Spring
8	Spring winding tube assy.
9	Torsion arm & linkage assy.
10	Gusset with bearing
11	Bearing, torsion arm
12	Gusset with retainer
13	Gusset
14	Lip linkage tab
15	Lip linkage arms (2 ea. req.)
16	Linkage pins (2 ea. req.)
17	Cotter Keys (2 ea. req.)

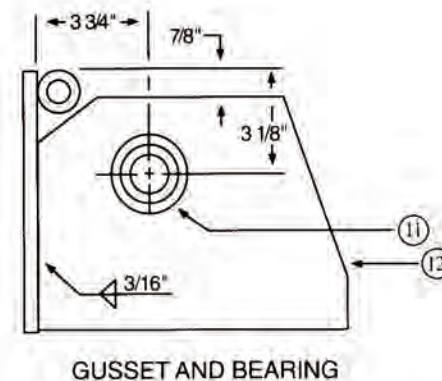
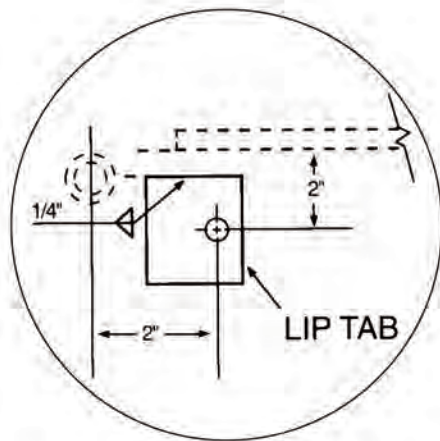

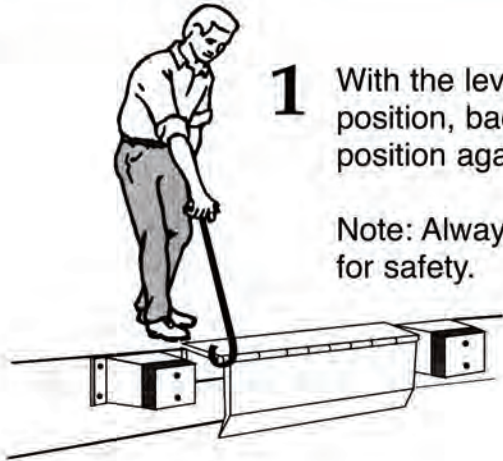

1 With the leveler in the stored position, back the truck into position against the bumpers.

Note: Always chock the wheels for safety.

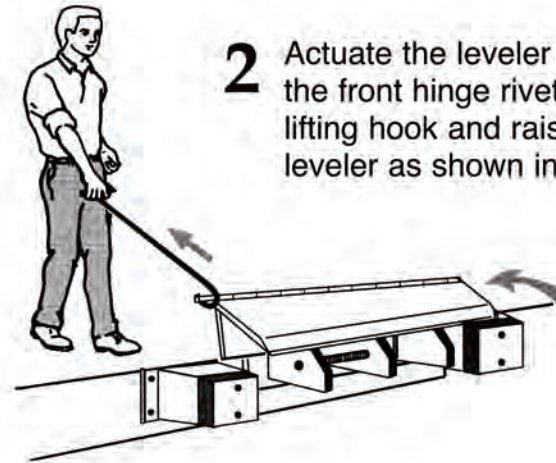

2 Actuate the leveler by hooking the front hinge rivet with the lifting hook and raising the leveler as shown in Fig. 2.

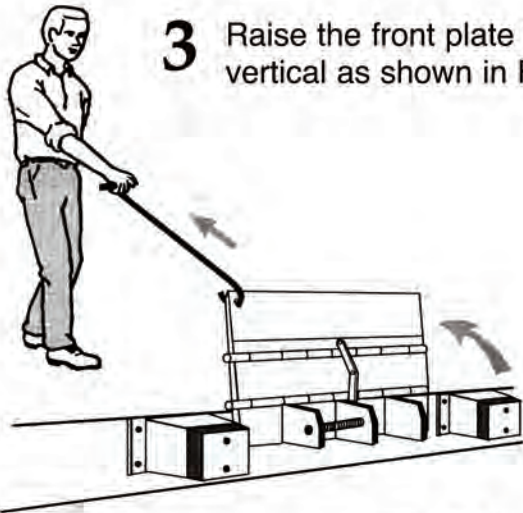

3 Raise the front plate (lip) to vertical as shown in Fig. 3.

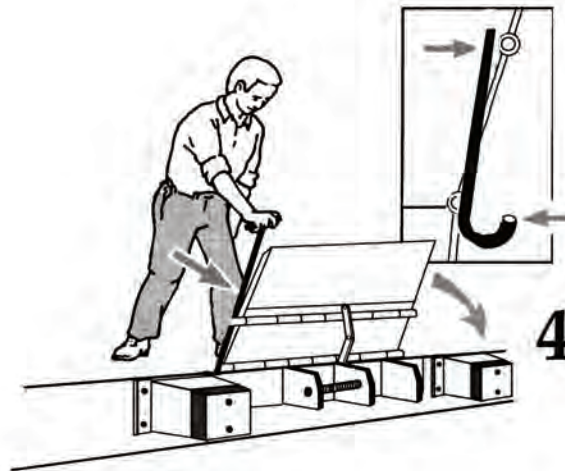

4 Place the lifting hook against the dock edge and behind the front hinge rivet and push the leveler into the truck as shown in Fig. 4.

5 When the truck departs the leveler automatically returns to the stored position.

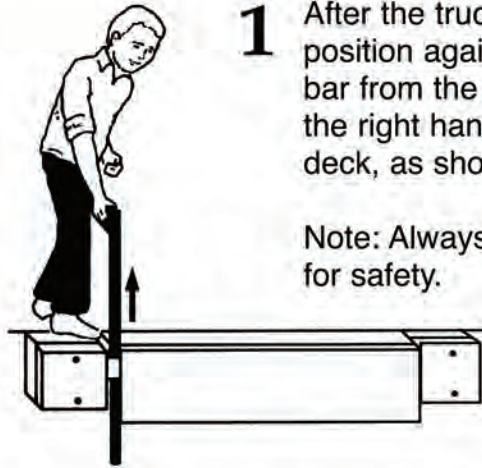

1 After the truck has backed into position against the bumpers, lift bar from the stored position on the right hand side below the deck, as shown in Fig. 1.

Note: Always chock the wheels for safety.

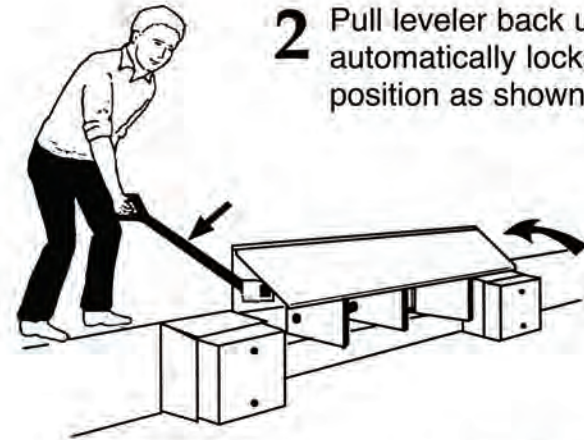

2 Pull leveler back until it automatically locks in raised position as shown in Fig. 2.

VERY IMPORTANT!

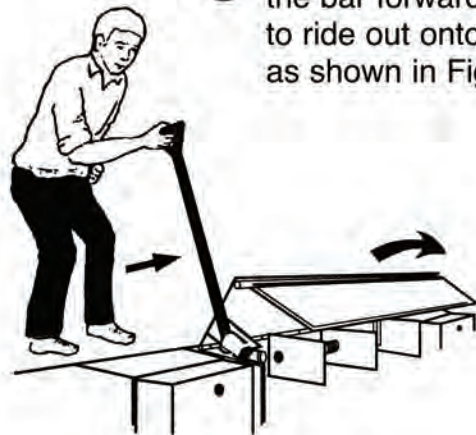

3 Using the bar as a lever, push the bar forward, allowing the lip to ride out onto the truck bed, as shown in Fig. 3.



4 To prevent damage to the bar, return it to the stored position.

5 Recycle the leveler to the closed position prior to truck departure

SECTION 4

**PARTS DIAGRAM
EDGE OF DOCK**

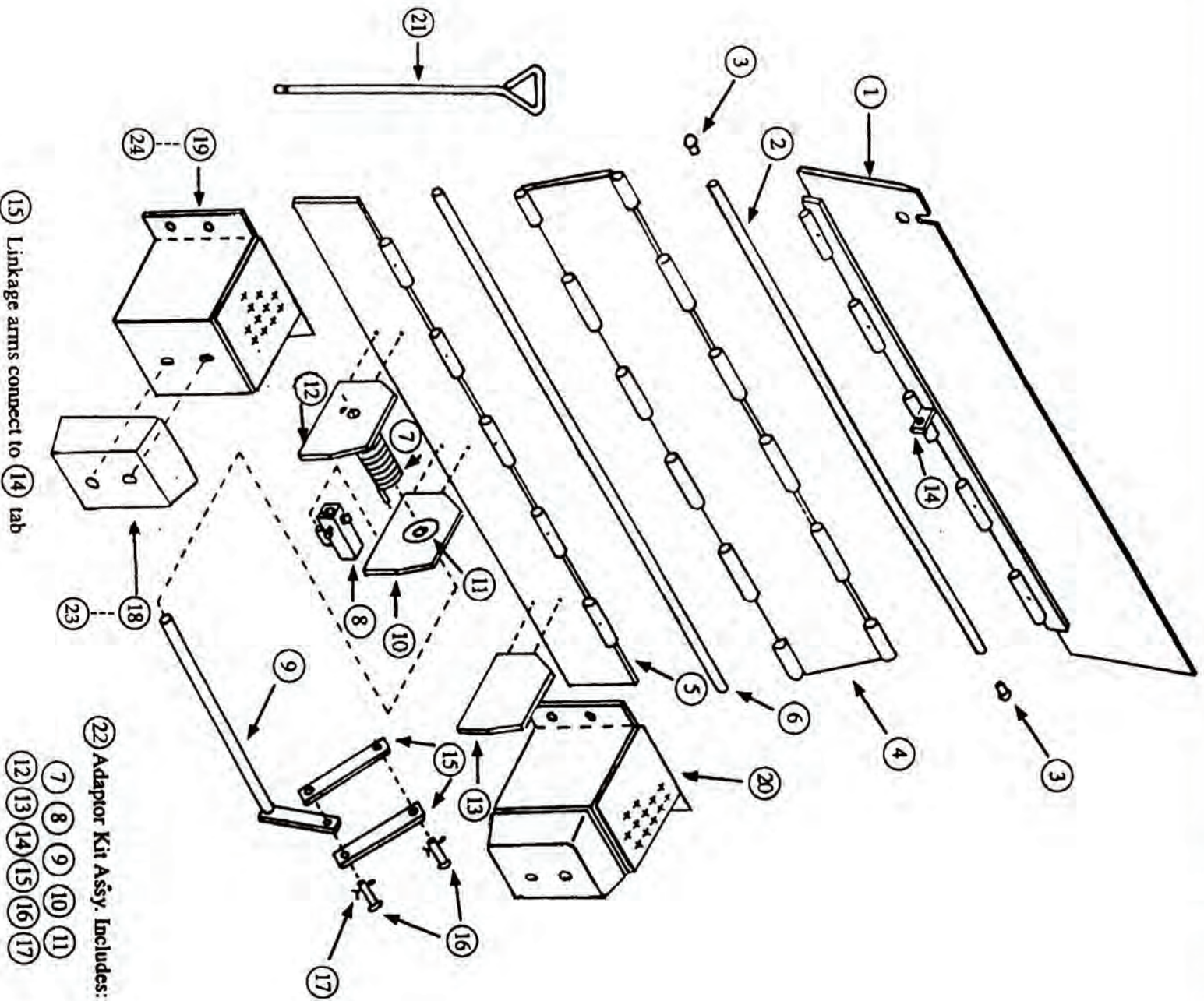

SECTION 4

PARTS LISTS EDGE OF DOCK

Item #	Model Description	ED66M		ED72M		ED66M17		ED72M17		ED66MH		ED72MH		PO66M		PO72M	
1	Lip Plate Assy.	154	182	175	297	179	0724	185	1767								
2	Lip Hinge Pin	115	189	115	189	115	189	115	189								
3	Rivet (2 ea. for ea. pin)	188	188	188	188	188	188	188	188								
4	Center Plate Assy.	153	183	153	183	180	737	186	1768								
5	Base Plate Assy.	151	184	151	184	151	184	151	184								
6	Base Hinge Pin	115	189	115	189	115	189	115	189								
7	Torsion Spring																
8	Winding Assy. —Assy.	111A	111A	111A	111A	111A	111A	111A	111A								
9	Torsion Arm & Linkage Assy.	149	149	149	149	149	149	149	149								
10	Gusset w/Bearing	156	156	156	156	156	156	156	156								
11	Bearing, Torsion Arm	128	128	128	128	128	128	128	128								
12	Gusset w/Retainer	157	157	157	157	157	157	157	157								
13	Gusset	107	107	107	107	107	107	107	107								
14	Lip Tab	122	122	122	122	122	122	122	122								
15	Lip Linkage Arms (2 ea. req.)	123	123	123	123	123	123	123	123								
16	Linkage Pins (2 Ea. req.)	193	193	193	193	193	193	193	193								
17	Pin Keys (2 ea. req.)	235	235	235	235	235	235	235	235								
18	Molded Cord Rubber (4x10x13) - 2 Hole	9243	9243	9243	9243	9243	9243	9243	9243								
19	Bump Block Steel w/Cover	9270	9270	9270	9270	9270	9270	9270	9270								
20	Bump Block Assembly	1771	1771	1771	1771	1771	1771	1771	1771								
	Bump Blk Assy. (opt. 18")	208	208	208	208	208	208	208	208								
21	Lifting Hook	141	141	141	141	141	141	141	141								
22	Adapter Kit Assy. ED66M/ED72M	192	192	192	192	192	192	192	192								
23	Molded Cord Rubber (4x12x13) - 4 Hole	137	137	137	137	137	137	137	137								
24	Bump Block Steel w/Cover	138	138	138	138	138	138	138	138								
	For 4 Hole Rubber																

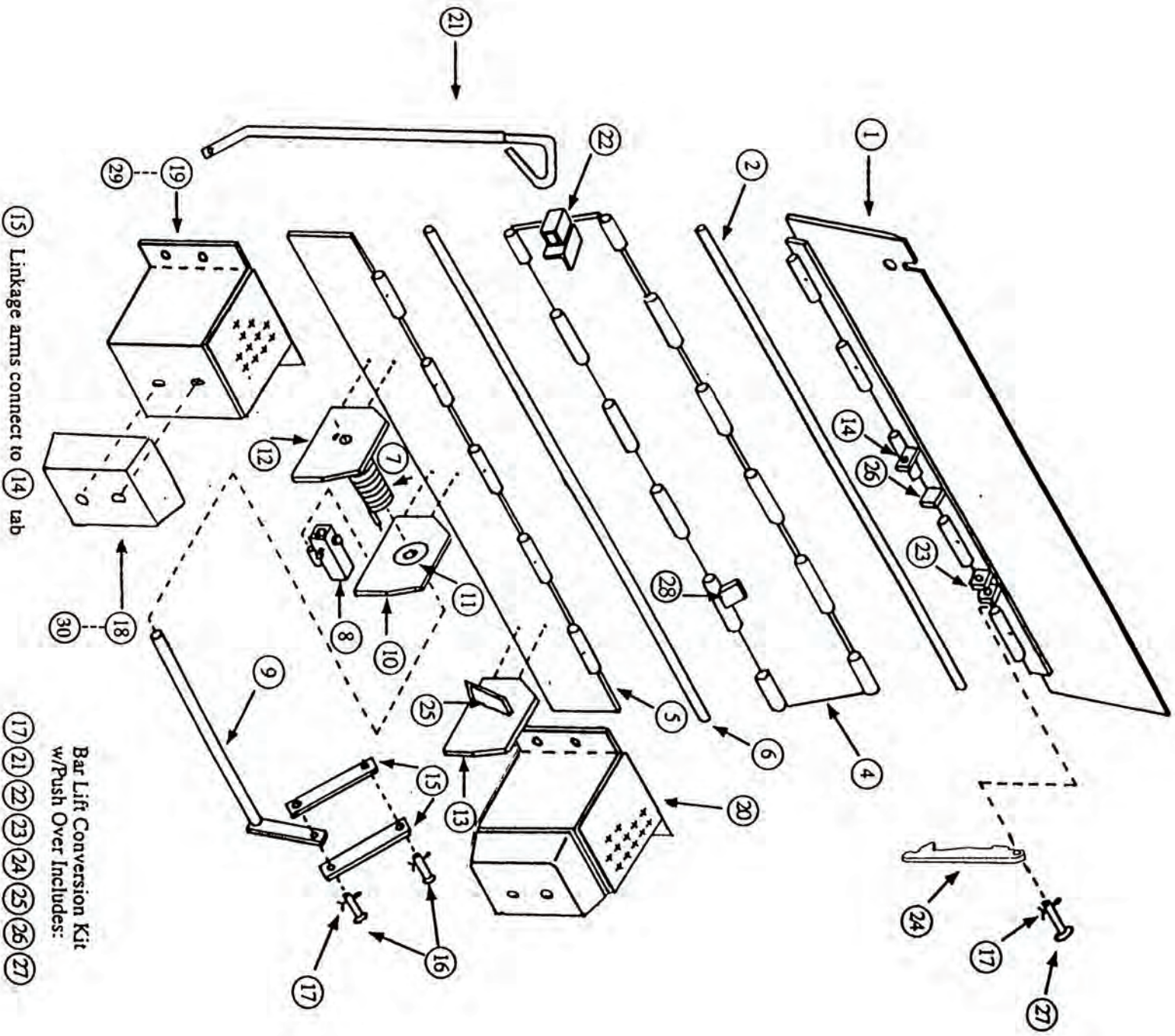

15 Linkage arms connect to 14 tab

Bar Lift Conversion Kit
w/Push Over Includes:
17 21 22 23 24 25 26 27

SECTION 4

PARTS LIST BAR LIFT EDGE OF DOCK

Item #	Model Description	Model										
		BL66	BL72	BL6617	BL7217	BL66H	BL72H	BL78	BL84			
1	Lip Plate Assy.	2345	182B	175	297	989	724	1761	1764			
2	Lip Hinge Pin	115	189	115	189	115	189	1462	481			
4	Center Plate Assy.	153	183	153	183	180	737	1762	1765			
5	Base Plate Assy.	151	184	151	184	151	184	1763	1766			
6	Base Hinge Pin	116	190	116	189	116	189	1463	481			
7	Torsion Spring											
8	Winding Assy.											
9	Torsion Arm & Linkage Assy.	111A	111A	111A	111A	111A	111A	111A	111A			
10	Gusset w/Bearing	149	149	149	149	149	149	149	149			
11	Bearing, Torsion Arm	156	156	156	156	156	156	156	156			
12	Bearing, Torsion Arm	128	128	128	128	128	128	128	128			
13	Gusset w/Retainer	157	157	157	157	157	157	157	157			
14	Gusset	107	107	107	107	107	107	107	107			
15	Lip Tab	122	122	122	122	122	122	122	122			
15	Lip Linkage Arms (2 ea. req.)	123	123	123	123	123	123	123	123			
16	Linkage Pins (2 Ea. req.)	193	193	193	193	193	193	193	193			
17	Pin Keys (3 ea. req.)	235	235	235	235	235	235	235	235			
18	Molded Cord Rubber (4x10x13)	9243	9243	9243	9243	9243	9243	9243	9243			
19	Bump Block Steel w/Cover - 2 Hole	9270	9270	9270	9270	9270	9270	9270	9270			
20	Bump Block Assembly	1771	1771	1771	1771	1771	1771	1771	1771			
	Bump Blk. Assy. (opt. 18")	208	208	208	208	208	208	208	208			
21	Bar Lift Handle Assembly			2006	2006	2006	2006	2006	2006			
22	Bar Lift Holder Assembly			2012	2012	2012	2012	2012	2012			
23	Lip Linkage Tabs (2 ea. req.)	445	445	445	445	445	445	445	445			
24	Lip Kickout Bar	446R2	446R2	446R2	446R2	446R2	446R2	446R2	446R2			
25	Lip Release Tab	1405	1405	1405	1405	1405	1405	1405	1405			
26	Lip Stop Tab	1017	1017	1017	1017	1017	1017	1017	1017			
27	Lip Kickout Pin	251	251	251	251	251	251	251	251			
	Bar Lift Conversion Kit w/Push Over			[—No. 453 & 1727, All Models—]								
28	Kick Out Bar Guide	1017	1017	1017	1017	1017	1017	1017	1017			
29	Molded Cord Rubber (4x12x13) - 4 Hole	137	137	137	137	137	137	137	137			
30	Bump Block Steel w/Cover	139	139	139	139	139	139	139	139			
	For 4 Hole Rubber											



Warranty Procedure

The information on the Warranty Claim Request Form must be provided with all warranty claims.

When a call is received with a warranty problem a Customer Service number (CSF ####) will be issued for that problem only and cannot be used again without prior approval. This number must be on all invoices submitted for payment and on all correspondence.

Before and after pictures of all the work performed must be supplied with each claim. If you take digital pictures, e-mail them to connerh@pioneerleveler.com. If you use a film camera forward the film to Pioneer Dock Equipment. PO Box 338 Spring Hill Tn 37174,
Attn: Warranty Dept.

No claim will be considered for processing without the required information.

Pioneer's warranty policy for labor (once approved) requires a formal invoice from the customer performing the warranty. Pioneer must receive labor invoice within 30 days of warranty authorization. Upon receipt of labor invoice, a check will be processed.

Replacement Part under Warranty

Any replacement parts will be invoiced and a credit will be given when the damaged parts are returned to Pioneer. Pioneer will determine the only exception, if the parts are not to be returned. A copy of the credit memo will be sent to your billing address. If a check payment is required, the request must be in writing. The request then has to be approved by Pioneer's accounts payable department.

Replacement parts will be sent at Pioneer's discretion either UPS ground or OTR truck. Any other request for shipments will be charged to the dealer. I.e. UPS next day-FedEX etc.

All returned parts will be issued a Return Goods Authorization Number (RGA #####). A form will be faxed to you with this number, the signed copy is to be faxed to 1-931-486-0316 or returned with the parts. The Return Authorization is only good for 30 days. **The RGA # must be listed on all returns, using the RGA form as a packing list.**

No credits will be issued without proper authorization. **No Credit will be given on non-Pioneer parts.**

A copy of the credit memo will be sent to your billing address. The credit will be given against the invoice issued for the replacement parts.

Any questions regarding Warranty or Return Authorization should be directed to Customer Service at connerh@pioneerleveler.com or 1-866-728-6195.



Warranty claim request form

The Following Information Must Be Supplied To Process Any Claim

Dealer Name: * _____

Contact Person: * _____

Pioneer Invoice Number : _____ Date Of Purchase: _____

End User Name And address:

Name: _____

Address: _____

City: _____ State: _____ Zip: _____

Product: _____

Model Number: * _____ Serial Number: * _____

Customer Complaint: *

Scope of Service Performed: * _____

Estimated Repair: Hours: * _____ \$ * _____

If multiple repairs list hours and \$ for each item.
Pioneer requires an invoice for all claims requiring a payment.

***Before And After Pictures Must Be Supplied With All Work Performed**

Purchase a disposable camera and send it to Pioneer along with the receipt.

***Required to process all warranty claims.**

NOTES

EDGE OF DOCK WARRANTY

All PIONEER DOCK LEVELERS carry a comprehensive structural warranty. PIONEER guarantees its EDGE OF DOCK LEVELERS against defects in material and workmanship for a period of TWO (2) years, beginning at Date of Shipment.

PIONEER accepts full responsibility for the cost of materials, labor and freight for any warranty claim and reserves the right to either repair or replace any defective parts. PIONEER'S STANDARD WARRANTY PROCEDURES MUST BE FOLLOWED.

A claim for breach of warranty will be honored if the product has been properly installed, maintained and operated within its capacity, and not damaged by abuse.

PIONEER SHALL NOT BE LIABLE FOR LOSS OF USE OF ANY EQUIPMENT OR INCIDENTAL DAMAGES. PIONEER EXPRESSLY DISCLAIMS ANY AND ALL IMPLIED WARRANTIES.

All PIONEER products meet or exceed Federal Occupational Safety and Health Act Standards, Commercial Standards 202-56, and American Society of Mechanical Engineers Specifications ANSI MH14.1-84.

Pioneer reserves the right to make product improvement at any time without prior notice.

Warranty Phone # 1-866-728-6195

0750017