

# "SLR975" Series Automatic Truck Restraint Detail

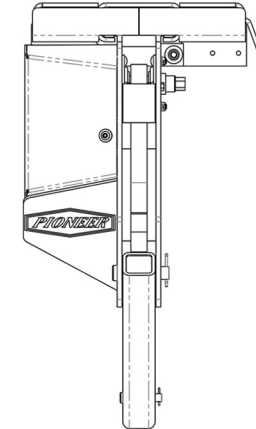

TOP VIEW

ISOMETRIC VIEW

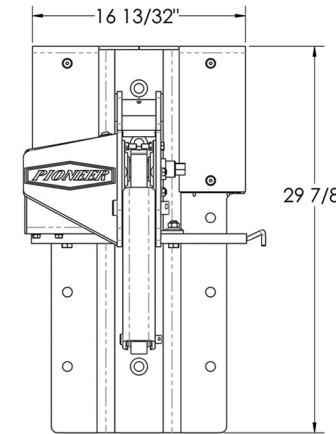
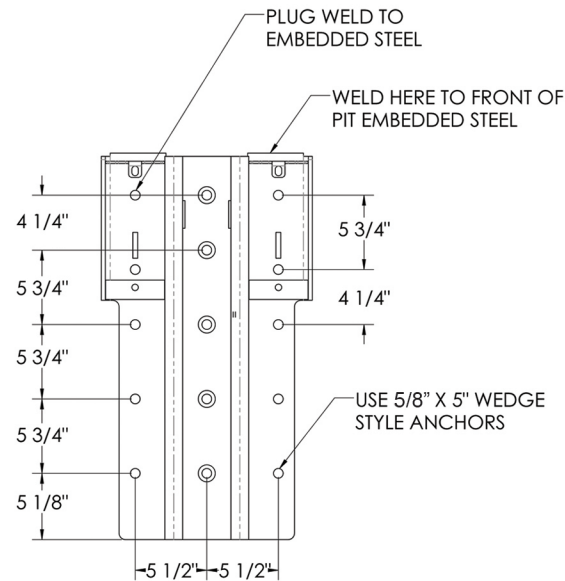
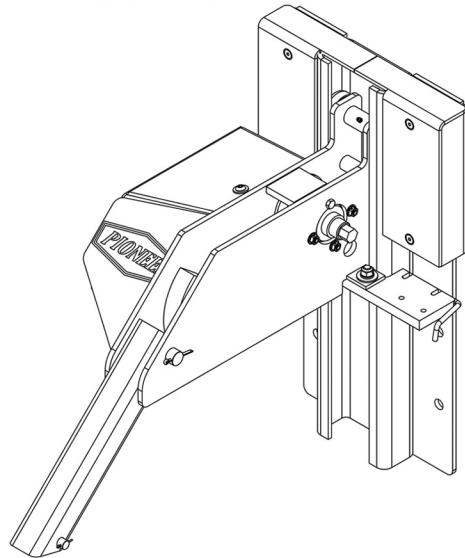

FRONT VIEW



PO Box 338 • Spring Hill, Tennessee 37174  
 931.486.2296 • 800.251.3382 • Fax: 931.486.0316  
 www.pioneerleveler.com

**JOB**

# "SLR975" Series Automatic Truck Restraint Submittal

## STANDARD FEATURES

- ◆ Automatic unit provides in excess of 32,000 lbs. restraining force
- ◆ Wide 9" - 27" operating range
- ◆ Captures and holds all legal ICC bars
- ◆ Designed to meet 1998 ICC regulations
- ◆ Positive contact hook automatically floats up or down with trailer
- ◆ Automatic inside/outside light system
- ◆ Complete inside/outside sign package included
- ◆ Bolt hole pattern designed for optimal holding force
- ◆ Low maintenance

## OPTIONAL FEATURES

- Steel mounting plate for new construction

D Steel blackouts for bumper projections greater than 4" including edge-of-dock levelers

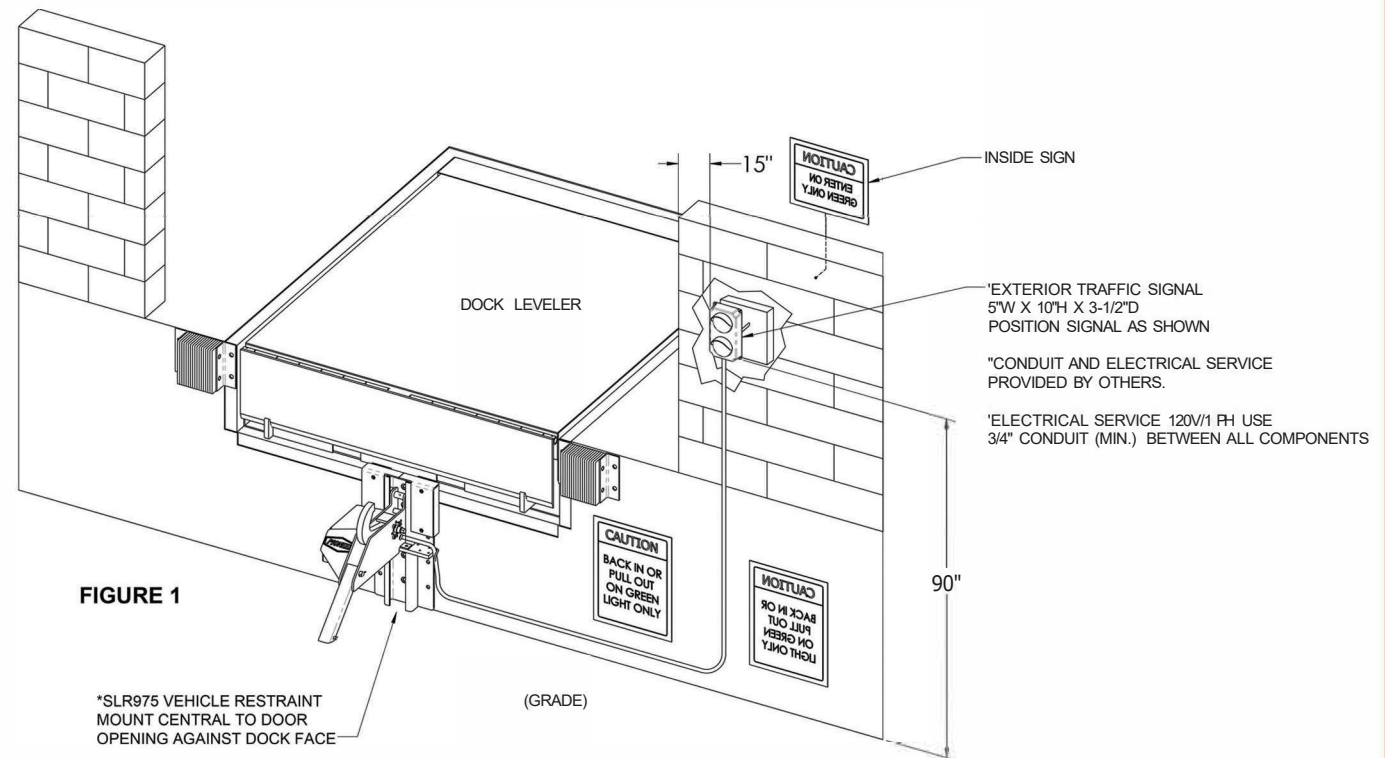

PO Box 338 • Spring Hill, Tennessee 37174  
 931.486.2296 • 800.251.3382 • Fax: 931.486.0316  
[www.pioneerleveler.com](http://www.pioneerleveler.com)